

(19) World Intellectual Property Organization  
International Bureau



(43) International Publication Date  
19 June 2003 (19.06.2003)

PCT

(10) International Publication Number  
**WO 03/049699 A2**

- (51) International Patent Classification<sup>7</sup>: **A61K**
- (21) International Application Number: PCT/US02/39434
- (22) International Filing Date: 9 December 2002 (09.12.2002)
- (25) Filing Language: English
- (26) Publication Language: English
- (30) Priority Data:  
10-2001-0078244  
11 December 2001 (11.12.2001) KR  
60/348,452 16 January 2002 (16.01.2002) US  
60/381,503 17 May 2002 (17.05.2002) US  
60/407,741 3 September 2002 (03.09.2002) US
- (81) Designated States (*national*): AE, AG, AL, AM, AT, AU, AZ, BA, BB, BG, BR, BY, BZ, CA, CH, CN, CO, CR, CU, CZ, DE, DK, DM, DZ, EC, EE, ES, FI, GB, GD, GE, GH, GM, HR, HU, ID, IL, IN, IS, JP, KE, KG, KP, KR, KZ, LC, LK, LR, LS, LT, LU, LV, MA, MD, MG, MK, MN, MW, MX, MZ, NO, NZ, OM, PH, PL, PT, RO, RU, SD, SE, SG, SK, SL, TJ, TM, TN, TR, TT, TZ, UA, UG, UZ, VN, YU, ZA, ZM, ZW.
- (84) Designated States (*regional*): ARIPO patent (GH, GM, KE, LS, MW, MZ, SD, SL, SZ, TZ, UG, ZM, ZW), Eurasian patent (AM, AZ, BY, KG, KZ, MD, RU, TJ, TM), European patent (AT, BE, BG, CH, CY, CZ, DE, DK, EE, ES, FI, FR, GB, GR, IE, IT, LU, MC, NL, PT, SE, SI, SK, TR), OAPI patent (BF, BJ, CF, CG, CI, CM, GA, GN, GQ, GW, ML, MR, NE, SN, TD, TG).

**Published:**

— *without international search report and to be republished upon receipt of that report*

*For two-letter codes and other abbreviations, refer to the "Guidance Notes on Codes and Abbreviations" appearing at the beginning of each regular issue of the PCT Gazette.*

- (71) Applicant: **SUN BIO, INC.** [US/US]; 1685 Suncrest Court, Walnut Creek, CA 94596 (US).
- (72) Inventors: **ROSEN, Perry**; 26 Sunset Drive, North Caldwell, NJ 07006 (US). **NHO, Kwang**; 1685 Suncrest Court, Walnut Creek, CA 94596 (US).
- (74) Agents: **EPSTEIN, William, H.** et al.; Gibbons, Del Deo, Dolan, Griffinger & Vecchione, One Riverfront Plaza, Newark, NJ 07102 (US).



**WO 03/049699 A2**

(54) Title: NOVEL MONOFUNCTIONAL POLYETHYLENE GLYCOL ALDEHYDES

(57) Abstract: Novel monofunctional polyethylene glycol aldehyde for pegylating therapeutically active proteins to produce pegylated protein conjugates which retain a substantial portion of their therapeutic activity and are less immunogenic than the protein from which the conjugate is derived and a new synthesis for preparing such aldehydes.

**NOVEL MONOFUNCTIONAL POLYETHYLENE GLYCOL ALDEHYDES****BACKGROUND**

Therapeutic proteins which are generally administered by intravenous injection may  
5 be immunogenic, relatively water insoluble, and may have a short *in vivo* half-life. The  
pharmacokinetics of the particular protein will govern both the efficacy and duration of effect  
of the drug. It has become of major importance to reduce the rate of clearance of the protein  
so that prolonged action can be achieved. This may be accomplished by avoiding or  
inhibiting glomerular filtration which can be effected both by the charge on the protein and  
10 its molecular size (Brenner et al., (1978) Am.J.Physiol.,234,F455). By increasing the  
molecular volume and by masking potential epitope sites, modification of a therapeutic  
polypeptide with a polymer such as polyethylene glycol (PEG) has been shown to be  
efficacious in reducing both the rate of clearance as well as the antigenicity of the protein.  
Reduced proteolysis, increased water solubility, reduced renal clearance, and steric hindrance  
15 to receptor-mediated clearance are a number of mechanisms by which the attachment of a  
PEG polymer to the backbone of a polypeptide may prove beneficial in enhancing the  
pharmacokinetic properties of the drug. Thus Davis et al., U.S. Pat. No. 4,129,337 discloses  
conjugating PEG to proteins such as enzymes and insulin to produce a less immunogenic  
product while retaining a substantial proportion of the biological activity.

20 PEG modification requires activation of the PEG polymer which is accomplished by  
the introduction of an electrophilic center. The PEG reagent is now susceptible to  
nucleophilic attack, predominantly by the nucleophilic epsilon-amino group of a lysyl  
residue. Because of the number of surface lysines present in most proteins, the PEGylation  
process can result in random attachments leading to mixtures which are difficult to purify and  
25 which may not be desirable for pharmaceutical use.

There are a large variety of active PEGs which have been developed for the modification of proteins by means of a covalent attachment which requires the formation of a linking group between PEG and protein (see for example Zalipsky, et al., and Harris et. al., in: Poly(ethylene glycol) Chemistry: Biotechnical and Biomedical Applications; (J.M. Harris ed.) Plenum Press: New York, 1992; Chap.21 and 22). Some of these reagents are, to various degrees, unstable in the aqueous medium in which the PEGylation reaction occurs. In addition, the conjugation process often results in the loss of *in vitro* biological activity which is due to several factors foremost of which being a steric interaction with the proteins active sites. A desired property therefore of a new reagent would be one that is not susceptible to degradation in an aqueous medium and one which may be employed to affect the site specific modification of a protein. A PEG aldehyde may be considered such a reagent. For site specific N-terminal pegylation see Pepinsky et al., (2001) JPET, 297,1059 (Interferon- $\beta$ -1a) and U.S.Pat.No.5,824,784(1998) to Kinstler et al., (G-CSF). The use of a PEG-aldehyde for the reductive amination of a protein utilizing other available nucleophilic amino groups, is described in U.S.Pat. 4,002,531(1977) to Royer, in EP O 154 316, by Wieder et al., (1979) J.Biol.Chem. 254,12579, and Chamow et al., (1994) Bioconjugate Chem. 5, 133.

### SUMMARY OF INVENTION

In accordance with this invention, it has been discovered that aldehydes of the formula

20 IA

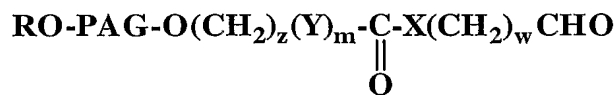

wherein R is hydrogen or lower alkyl; X and Y are individually selected from -O - or - NH- with the proviso that X is NH when m is 1 and Y is -O-; PAG is a divalent residue of

polyalkylene glycol resulting from removal of the terminal hydroxy groups, having a molecular weight of from 1,000 to 100,000 Daltons, z is an integer of from 2 to 4, m is an integer of from 0 to 1, and w is an integer of from 2 to 8, preferably 2 to 4.

5

**IB**

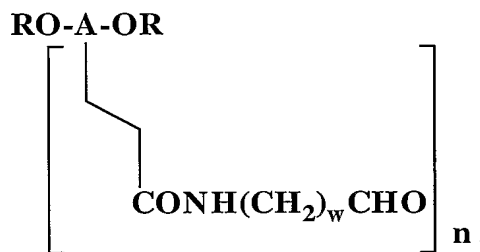

wherein A is a polyethylene glycol residue with its two terminal hydroxy groups being removed having a molecular weight of from 1,000 to 100,000 Daltons and having a valence of from 1 to 5; n is an integer of from 1 to 5 which integer is the same as the valence of A; R and w are as above.

10

**IC**

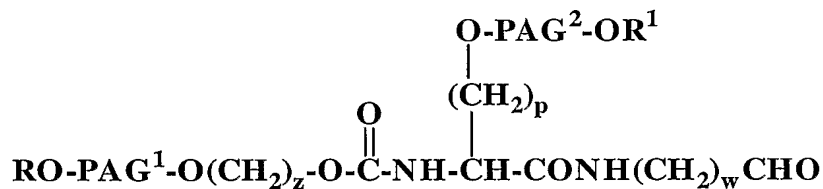

15

wherein PAG<sup>1</sup> and PAG<sup>2</sup> are independently divalent residues of poly lower alkylene glycol resulting from removal of the two terminal hydroxy groups with the PAG<sup>1</sup> and PAG<sup>2</sup> residues having a combined molecular weight of from 1,000 to 100,000 Daltons; R and R<sup>1</sup> are individually lower alkyl or hydrogen and

20

w is as above and p is an integer of from 1 to 5; and z is as above.

are useful for conjugation to therapeutically active proteins to produce PAG Protein conjugates which retain a substantial portion of their therapeutic activity and are less immunogenic than the protein from which the conjugate is derived.

In accordance with this invention, a new synthesis has been found for the aldehyde of formula

**ID**

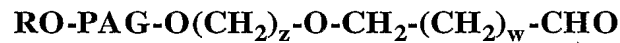

wherein R, PAG, z and w are as above.

which like the compound of formula IA, IB and IC, is a reagent for producing PAG protein conjugates.

#### **DETAILED DESCRIPTION**

The aldehyde reagents of formula IA, IB, IC and ID can be conjugated to therapeutically active proteins to produce therapeutically active protein conjugates which retain a substantial portion of the biological activity of the protein from which they are derived. In addition, the reagents of this invention are not susceptible to degradation in the aqueous medium in which the pegylation reaction is carried out. Furthermore, the aldehyde reagents of this invention can be conjugated to the protein in a controlled manner at the N-terminus. In this way, these aldehydes produce the desired conjugates and avoid random attachment leading to mixtures which are difficult to purify and which may not be desirable for pharmaceutical use. This is extremely advantageous since not only are the purification procedures expensive and time consuming but they may cause the protein to be denatured and thus bring about an irreversible change in the proteins tertiary structure.

The therapeutic proteins which can be conjugated in accordance with this invention can be any of the conventional therapeutic proteins. Among the preferred proteins are included interferon-alpha, interferon-beta, consensus interferon, G-CSF, GM-CSF, EPO, Hemoglobin, interleukins, colony stimulating factor, as well as immunoglobulins such as  
5 IgG, IgE, IgM, IgA, IgD and fragments thereof.

The term polyalkylene glycol designates poly(lower alkylene)glycol radicals where the alkylene radical is a straight or branched chain radical containing from 2 to 7 carbon atoms. The term "lower alkylene" designates a straight or branched chain divalent alkylene radical containing from 2 to 7 carbon atoms such as polyethylene, polypropylene, poly n-  
10 butylene, and polyisobutylene as well as polyalkylene glycols formed from mixed alkylene glycols such as polymers containing a mixture of polyethylene and polypropylene radicals and polymers containing a mixture of polyisopropylene, polyethylene and polyisobutylene radicals. The branched chain alkylene glycol radicals provide the lower alkyl groups in the polymer chain of from 2 to 4 carbon atoms depending on the number of carbon atoms  
15 contained in the straight chain of the alkylene group so that the total number of carbons atoms of any alkylene moiety which makes up the polyalkylene glycol substituent is from 2 to 7. The term "lower alkyl" includes lower alkyl groups containing from 1 to 7 carbon atoms, preferably from 1 to 4 carbon atoms, such as methyl, ethyl, propyl, isopropyl, etc. with methyl being especially preferred.

20 In accordance with a preferred embodiment of this invention, PAG in the compound in formulas IA, IC and ID is a polyethylene glycol residue formed by removal of the two terminal hydroxy groups. Further in accordance with this invention, PAG in the compound of formula IA, IC and ID, and the A in the compound of formula IB have molecular weights of from about 10,000 to 50,000 most preferably from about 20,000 to about 40,000. In the  
25 compound of formula IC it is generally preferred that the radicals  $PAG^1$  and  $PAG^2$  have a

combined molecular weight of from about 10,000 to 50,000 and most preferably from about 20,000 to 40,000. In the compound of formula IC it is generally preferred that p be an integer of from 1 to 5.

The aldehydes of compounds of formula IA, IB, IC and ID are used in forming polyalkyleneoxy protein conjugates. The aldehydes of this invention are intermediates for conjugation with the terminal amino group as well as other free amino groups on the protein to produce a therapeutically effective conjugate which has the therapeutic properties of the native protein. In addition the conjugates show a reduced rate of clearance and a decreased antigenicity as compared to that of the starting protein. In addition these conjugates have the beneficial properties of *in vivo* reduced proteolysis, increased water solubility, reduced renal clearance, and steric hindrance to receptor-mediated clearance. These enhanced properties when compared to the protein from which they are formed make them more effective therapeutic agents than the protein itself. The aldehydes of this invention are converted to their protein conjugates in accordance with the following reaction scheme:

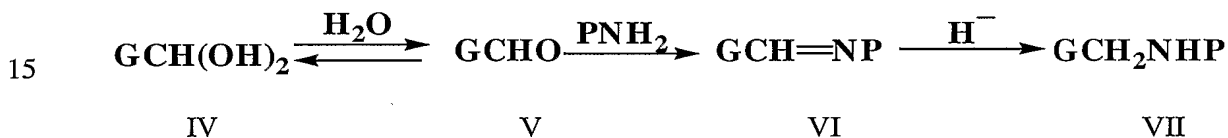

#### Scheme 1

wherein PNH<sub>2</sub> is a protein covalently attached to a PEG via a nucleophilic amino group of the protein.

In this reaction scheme, G-CHO in the compound of formula V is a composite of the compounds of IA, IB, IC and ID showing the reactive aldehyde group. In the compound of formula IB, the number of aldehyde groups are in accordance with the valence "n". If "n" were 4, the reaction in this scheme will take place at four different sites in this compound of formula V. In this reaction scheme, P is the protein containing a nucleophilic -NH<sub>2</sub> group which is conjugated with the compounds of formula IA, IB, IC and ID.

In the above reaction scheme, the compounds of formula IV and V are in equilibrium. The compound of formula IV is a conventional hydrate of the aldehyde of formula V. An equilibrium between the formulas IV and V is established when the compound of formula V is placed in an aqueous medium. The polyalkylene aldehyde of formula V is then reacted with the amine of the protein to form the imine linkage of formula VI. This imine linkage of the compound of formula VI is then reduced to an amine through the use of reducing agents such as cyanoborohydride to give the saturated conjugated protein of formula VII. The reaction whereby aldehydes are conjugated with proteins through reductive amination is set forth in U.S. Patent No. 4,002,531, EPO 154,316 and U.S. Patent No. 5,824,784.

In reacting the compound of formula V with P-NH<sub>2</sub>, one can control this reaction so that the aldehydes of formula IA, IB, IC and ID only react at a single site located at the N-terminus amine on the protein. This can be done by carrying out the reaction of the compound of formula V with P-NH<sub>2</sub> at a pH of from 5.5 to 7.5. In carrying out this reaction, various buffers which maintain the reaction media at a pH of from 5.5 to 7.5 can be used. If one wants the amination to proceed on more than one amino site on the protein, then one carries out the reaction at a pH of 8.0 and above, preferably at a pH of from 8 to 10. In this manner, amino groups, as well as, the N-terminal amino group on the protein are aminated with the PAG aldehydes of this invention.

The specific PEGylating reagents of formula IA, IB, IC and ID of this invention, are stable in aqueous medium and not subject to aldol decompositions under the conditions of the reductive amination reaction. The amino groups on proteins such as those on the lysine residues are the predominate nucleophilic centers for the condensation of the aldehydes of this invention. However by controlling the pH of the reaction one can produce a site specific introduction of a polyalkylene glycol polymer on the protein at the desired N-



terminus amino acid. When the compounds of formula IA are conjugated to a protein as is shown in Scheme 1, the resulting compound is:

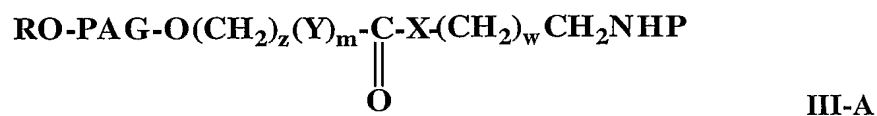

wherein R, P, Y, PAG, X, m, w and z are as above.

5           When the compound in formula IB is conjugated to a protein as is shown in Scheme 1, the resulting compound is:

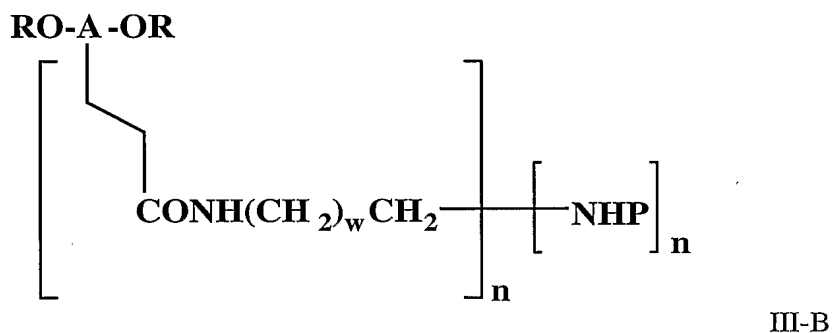

wherein A, P, n and w are as above.

10

When the compound of formula IC is conjugated to a protein as is shown in Scheme 1, the resulting compound is:

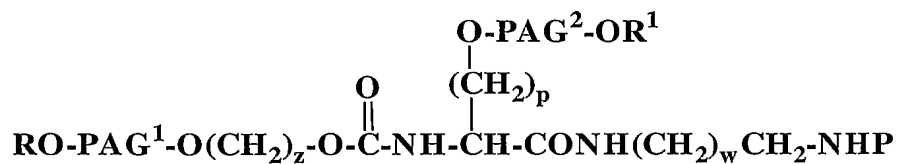

15

III-C

wherein R, R<sup>1</sup>, P, PAG<sup>1</sup>, PAG<sup>2</sup>, p, w and z are as above.

When the compound of formula ID is conjugated with the protein as is shown in Scheme 1 the resulting compound is:

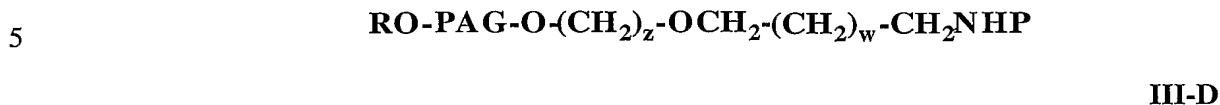

wherein R, PAG, P, z and w are as above.

In accordance with this invention, in formula I A, when m is 0 and X is -NH-, these compounds have the formula:

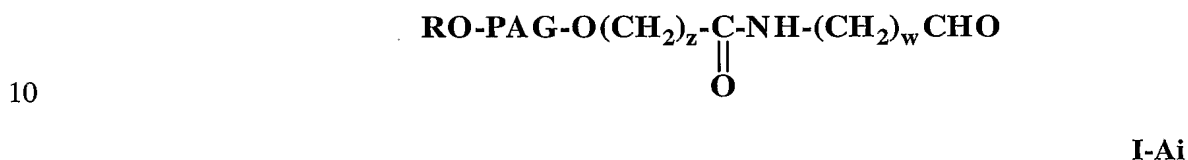

wherein R, PAG, z and w are as above.

The compound of formula I-Ai can be prepared by the following reaction scheme:

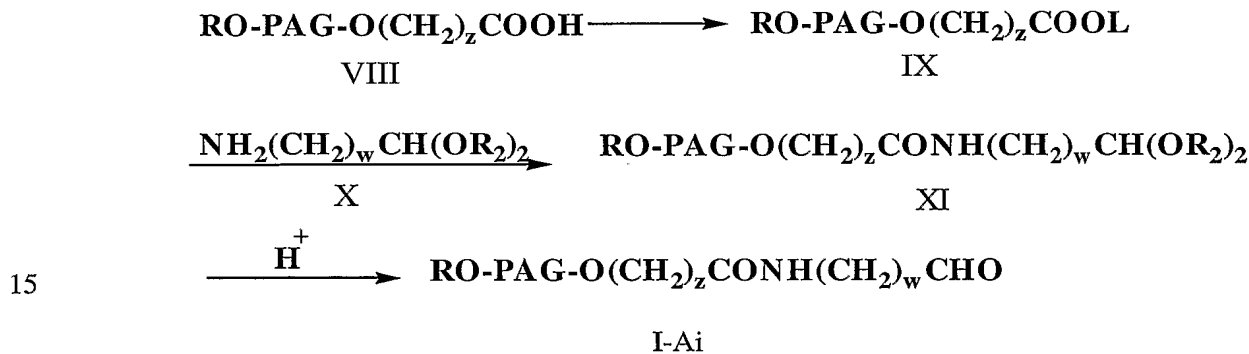

wherein R, PAG, z and w are as above, R<sub>2</sub> is lower alkyl. and

OL is a leaving group.

In the first step of the reaction to produce the compound of formula I-Ai, the acid group of the compound in formula VIII is activated to produce the compound of formula IX.

This is accomplished by activating the acid group on the compound of formula VIII with an activating agent to produce a leaving group such as an N-hydroxy succinimide group. Any conventional method of converting a carboxy group into an activating leaving group such as an N-hydroxy succinimide group can be utilized to produce the compound of formula IX. In the next step of the synthesis, the compound of formula IX containing the activating leaving group is reacted with the amine acetal compound of formula X to produce the compound of formula XI. This reaction to form the amide of formula XI is carried out by any conventional means of condensing an amine with an activated carboxylic acid group. The compound of formula XI has the aldehyde protected as its acetal, preferably a lower alkyl acetal. Any conventional aldehyde protecting groups such as other alkyl acetals can also be utilized. The acetal of formula XI can be hydrolyzed to form the corresponding aldehyde of formula I-Ai. Any conventional means of hydrolyzing an acetal to form the corresponding aldehyde can be utilized to convert the compound of formula XI into the corresponding aldehyde of formula I-Ai.

In the compound of formula IA where m is 1, X is -NH- and Y is -O-, this compound has the formula:

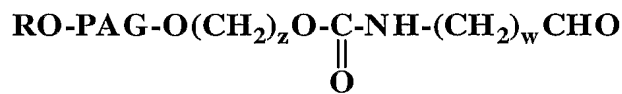

wherein R, PAG, z and w are as above.

I-Aii

The compound of formula I-Aii can be prepared by the following reaction scheme.

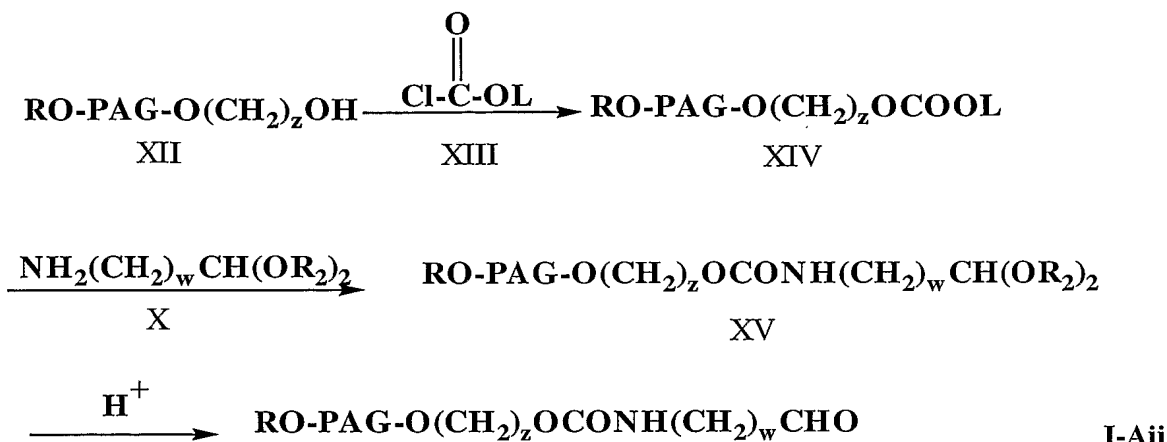

wherein OL, R, R<sub>2</sub>, PAG, z and w are as above.

In the above reaction scheme the compound of formula XII is first reacted with a compound of formula XIII which is a halo formate containing a leaving group.

- 5 Any conventional leaving group can be utilized as OL such as the leaving groups herein before mentioned. The preferred leaving group is a para-nitro phenol radical. One can utilize any of the conventional conditions for reacting an alcohol such as the compound of formula XII with a chloro formate such as the compound of formula XIII to produce the carbonate of formula XIV. The carbonate is then reacted with the amine of formula X to produce the
- 10 compound of formula XV. This reaction is carried out as described hereinbefore with regard to reacting the compound of formula IX with the compound of formula X. The compound of formula XV is then hydrolyzed to produce the compound of formula I-Aii in the conventional manner as described in connection with the hydrolysis of the compound of formula XI hereinbefore.

In accordance with another embodiment of this invention wherein the compound of formula IA, m is 1 and Y and X are both -NH-, this compound has the formula

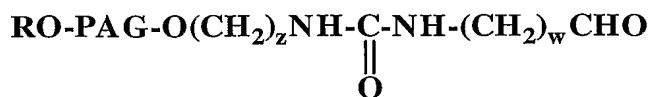

wherein R, PAG, z and w are as above.

5 The compound of formula I-Aiii can be produced by the following reaction scheme.

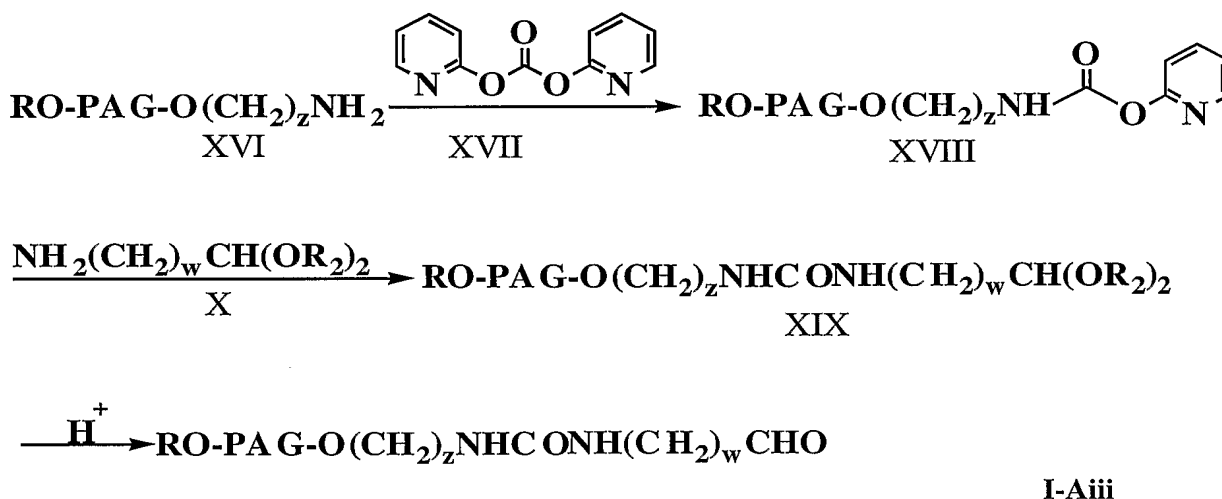

wherein R, PAG, z and w are as above and R<sub>2</sub> is lower alkyl.

10 In accordance with this embodiment, the compound of formula XVI is condensed with the compound of formula XVII in a halogenated hydrocarbon solvent to produce the compound of formula XVIII. This reaction utilizes conventional condensing procedures commonly used in reactions between an activated carbonate and an amine. The compound of formula XVIII is condensed with the amine of formula X in an inert organic solvent to  
15 produce the acetal of formula XIX. Any conventional inert organic solvent can be used in this reaction. The acetal of formula XIX is then hydrolyzed in acidic medium, in the manner described hereinabove to produce the compound of formula I-Aiii.

In the compound of formula IA where m is 1, Y is -NH- and X is -O- the compound has the following formula:



I-Aiii

5 wherein R, PAG, z and w are as above.

The compound of formula I-Aiv is prepared by means of the following reaction scheme:

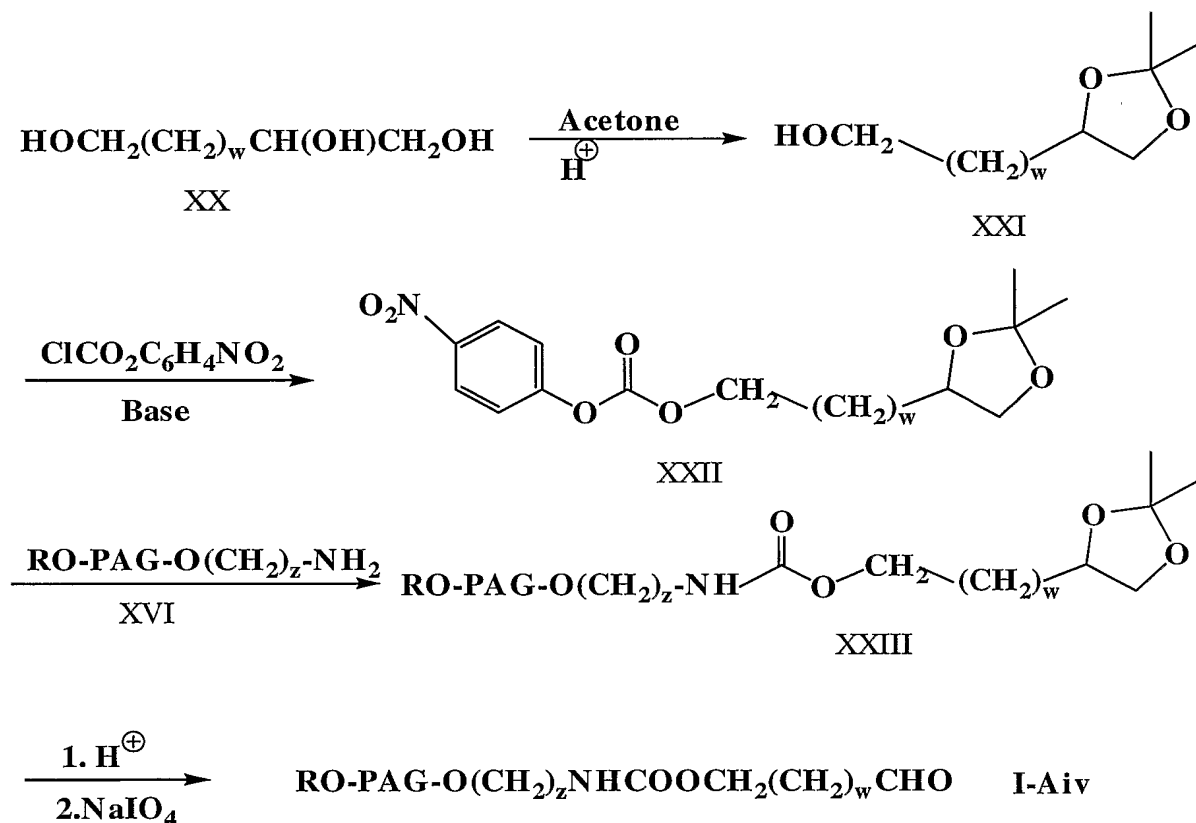

10 wherein R, PAG, z and w are as above.

In this reaction, the starting material of formula XX is a tri-hydroxy compound having two terminal primary hydroxy groups with the third hydroxy group being a secondary hydroxy group, vicinal to the one of the two terminal hydroxy groups. The

compound of formula XX is converted to its acetonide derivative of formula XXI by reacting the two vicinal hydroxy groups with acetone leaving free the third hydroxy group. Any conventional method of forming an acetonide derivative from the two vicinal hydroxy groups can be utilized to carry out this reaction to form the compound of formula XXI.

5 Reagents other than acetone, which are known to form cyclic acetals with 1,2-diols, may also be used. The free hydroxy group in the acetonide derivative of formula XXI is then activated with an activating group such as the p-nitro phenyl chloro formate as is shown in the reaction scheme. This reaction to convert the hydroxy group into an activated derivative is well known in the art. In this manner the compound of formula XXII is produced where  
10 the primary hydroxy group on the compound of formula XXI is activated. The compound of formula XXII is then condensed with the PEG amine of formula XVI to form the condensation product of formula XXIII. Any conditions conventional in reacting an activated alcohol with an amine to produce a urethane can be utilized to carry out this condensation. The compound of formula XXIII containing the acetonide is then cleaved  
15 utilizing conditions conventional in cleaving acetonides such as by treatment with a mild acid, to produce the corresponding di-hydroxy compound. The resulting dihydroxy groups are then oxidized with mild oxidizing agents such as a periodate oxidizing agent to produce the aldehyde of formula I-Aiv. Any conventional method of oxidizing a vicinal di-hydroxy compound to the corresponding aldehyde can be utilized to carry out this conversion.

20 The compound of formula IB is synthesized from RO-PEG-OR by reaction with acrylic acid by the following reaction scheme:

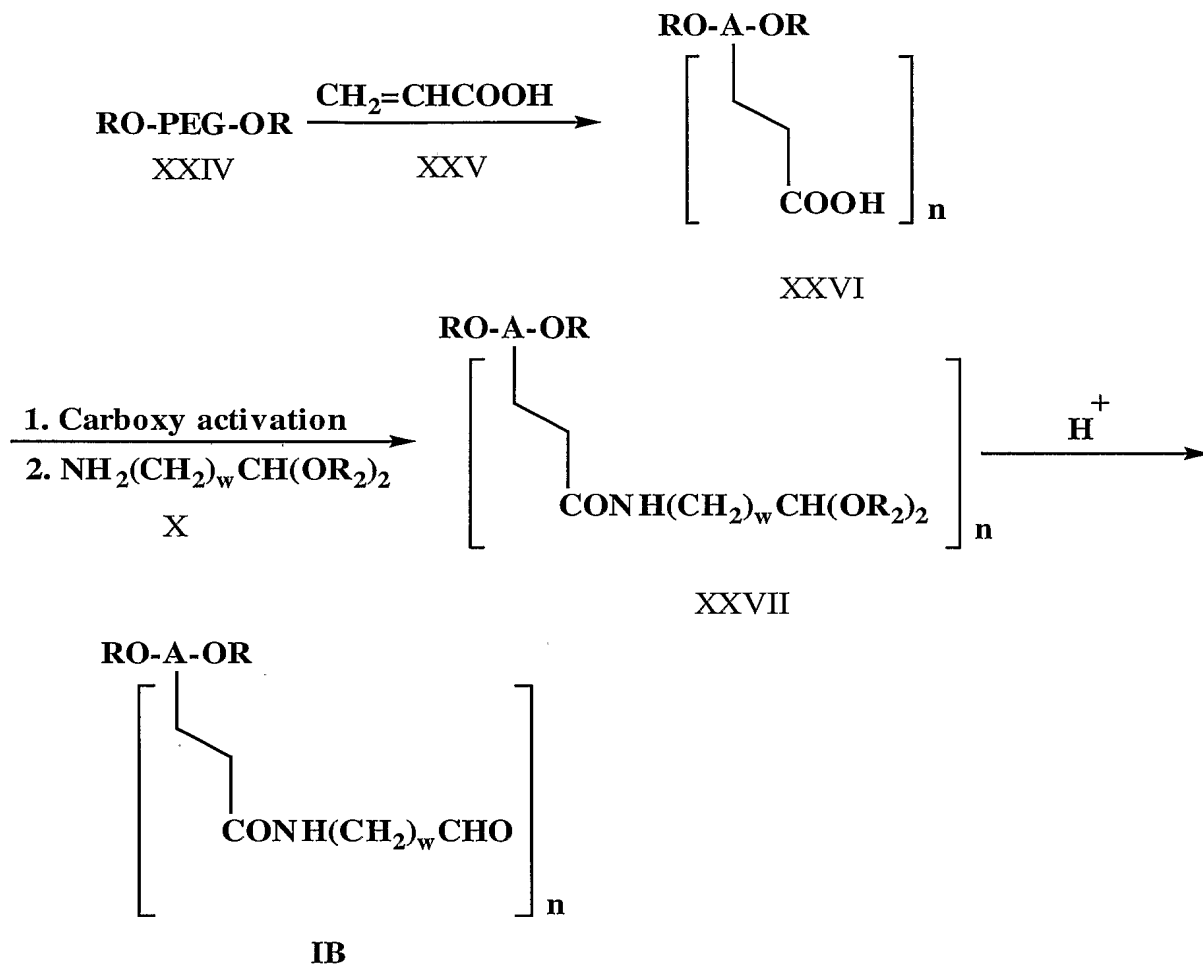

wherein A, R, w, n and R<sub>2</sub> are as above.

The acrylic acid of formula XXV can be reacted with the polyethylene glycol polymer of formula XXIV in the manner disclosed in U.S. Patent 4,528,334 Knopf, et al. to produce the compound of formula XXVI. The addition of acrylic acid across the various polyethylene glycol units in the series of polyethylene glycol residues designated A can be controlled so that from 1 to 5 bonds with the acrylic acid will take place to form the acrylic acid graft copolymer of formula XXVI. In this manner depending upon the conditions used, as disclosed in U.S. Patent 4,528,334, from 1 to 5 additions of acrylic acid will occur in the polyethyleneoxy chain. In accordance with this invention, an activated form of the carboxy group of the graft copolymer of formula XXVI is reacted with the compound of formula X to



form the compound of formula XXVII via amide formation. This reaction is carried out in the same manner as described hereinbefore in connection with the conversion of the compound of formula VIII to the compound of formula XI by reaction of the compound of formula X, through the use of an appropriate carboxy activating leaving group as in formula IX. The  
 5 acetal of formula XXVII can then be hydrolyzed to the compound of formula IB as described in connection with the conversion of the acetal of XI to the aldehyde of formula I-Ai.

The compound of formula IC can be prepared as shown by the following reaction scheme:

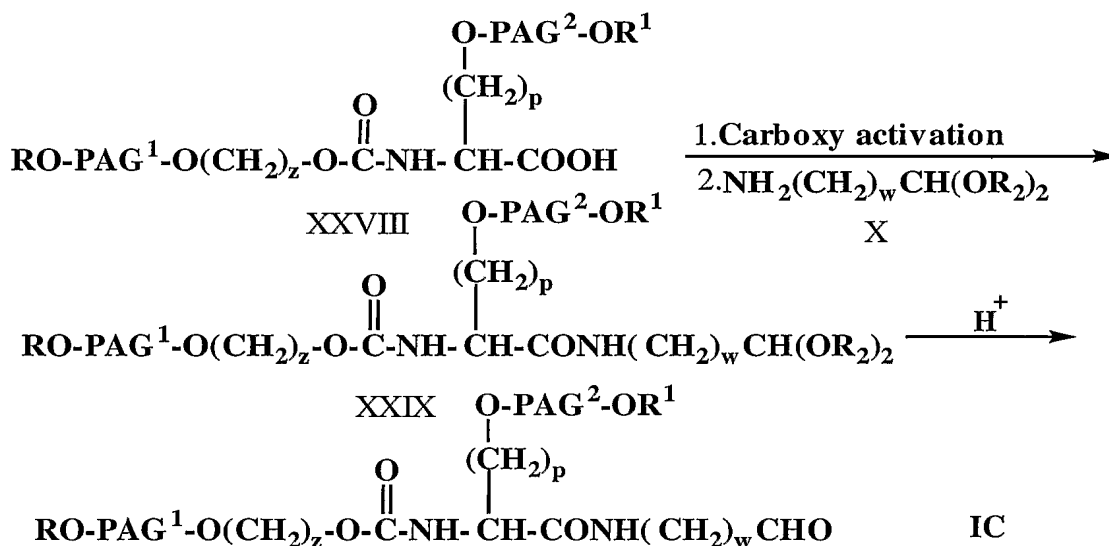

10

wherein R, V, R<sup>1</sup>, PAG<sup>1</sup>, PAG<sup>2</sup>, p, w and z are as above.

The derivative of formula IC is prepared from a compound of formula XXVIII by first activating the carboxyl group. This carboxyl group can be activated in the manner disclosed herein before with respect to the activation of the compound of the formula VIII to produce  
 15 the compound of the formula IX. The activated compound is then condensed with the amino acetal compound of formula X to produce the compound of formula XXIX in the same manner as described herein before in connection with the reaction of the compound of

formula IX with the compound of formula X to produce the compound of formula XI. The compound of formula XXIX is next converted to the compound of the formula IC by acid hydrolysis as described herein before in connection with the preparation of the compound of formula I-Ai from compound XI.

- 5 The compound of formula ID is produced from a compound of the formula XII via the following reaction scheme:

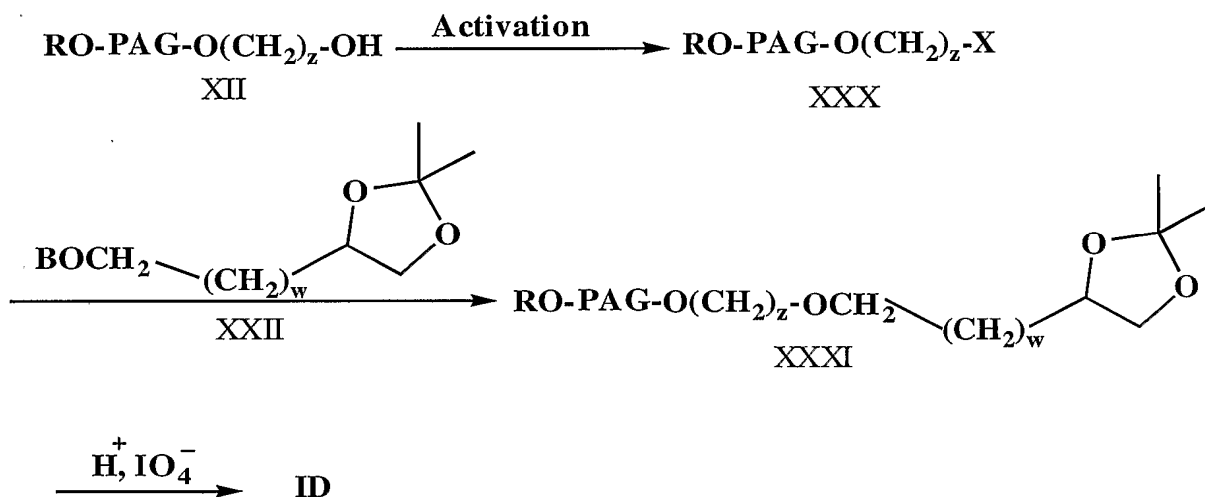

wherein R, PAG, and w and z are as above, X may be a halogen or sulfonate ester and B is an alkali metal.

- 10 In carrying out this process the compound of formula XII is converted to the compound of formula XXX by converting the hydroxy group on the compound of formula XII to an activating leaving group. The conversion of the terminal hydroxyl group of compound XII into an activated halide leaving group X, can be readily achieved by reaction with a conventional halogenating reagent such as thionyl bromide. On the other hand where
- 15 leaving groups, other than halides, are utilized, the hydroxy group of the compound of formula XXI may be converted to a sulfonate ester by reaction with a halide of the activating leaving group such as mesyl or tosyl chloride. Any conventional method for converting the

hydroxy group of compound XII to an activating leaving group such as a tosylate or mesylate or any of the aforementioned leaving groups can be utilized to produce the compound of formula XXX. This reaction may be carried out by reacting the formula XII with a halide of an activating leaving group such as tosyl chloride. The compound of formula XXX can then be condensed with the compound of formula XXI to form the compound of formula XXXI.

5 In this case the acetonide group is a precursor to the aldehyde of formula ID. In the case shown in the above reaction scheme where an acetonide is used, the acetonide can be hydrolyzed in mild acid. However any conventional means to produce the resulting dihydroxy compound from an acetonide can be used in this conversion. The dihydroxy

10 compound resulting from this hydrolysis can then be oxidized with a periodate to give the aldehyde of formula ID. This aldehyde can be reacted as set forth in Scheme 1 with a protein to form the conjugate of the compound of formula ID with the protein at the N-terminal amino acid of the protein as described hereinbefore.

The compound of formula ID can also be produced from a compound of the formula

15 XXI via the following reaction scheme.

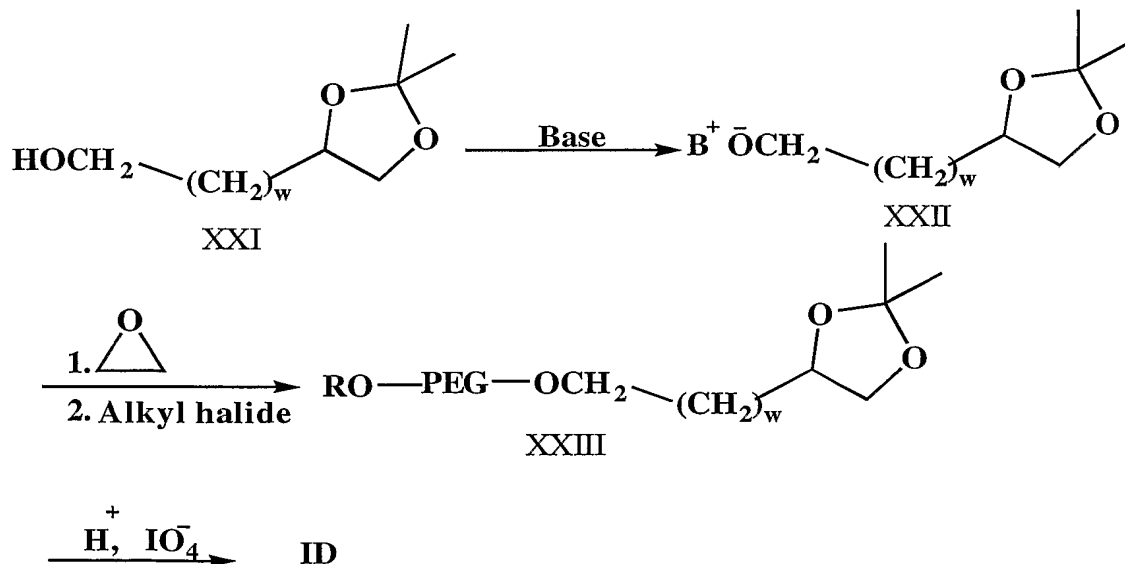

wherein R and w are as above, PEG is a divalent residue of polyethylene glycol resulting from removal of the terminal hydroxy groups, having a molecular weight of from 1,000 to 100,000 Daltons.

In this reaction process, the compound of formula XXI is reacted with any  
5 conventional organic alkali metal base such as potassium naphthalide to form the corresponding alkoxide XXII. Liquid ethylene oxide is then added under conventional polymeric conditions to a solution of XXII. In this manner the anionic ring opening and polymerization of ethylene oxide is allowed to proceed under conditions that are well known for the production of polyethylene glycol polymers. In addition the amount of  
10 polymerization of the ethylene oxide can be controlled by conventional means to produce a polyethylene polymer of any desired molecular weight. Any remaining ethylene oxide can then be removed from the reaction mixture and an excess of an alkyl halide such as methyl iodide reacted for several hours to form a terminal alkyl ether. The product, the compound of formula XXXIII, can then be isolated and converted to a compound of the formula ID in the  
15 same manner as described herein before for the conversion of the compound of formula XXXI to the compound of formula ID.

The aldehydes of formula IA, IB, IC and ID can be conjugated as described herein before with various proteins through an amine group on the protein by the process of reductive amination as disclosed in U.S. Patent 5,824,784 dated October 20, 1998. By means  
20 of regulating the pH (i.e. from 5.5 to 7.5) the aldehydes in this invention may condense at the N-terminus amino group of a protein so as to obtain a monoconjugate derivative. In this manner, the pegylating reagents of IA, IB, IC and ID can form site specific mono-conjugates with the N-terminal amino group of various proteins thereby avoiding the necessity of employing extensive purification or separation techniques. On the other hand, if higher pH's  
25 from about 8.5 and above are utilized, the reductive amination procedure will also involve the

various lysine amino groups which are available in the protein molecule. Among the preferred proteins for such conjugations are included G-CSF, GM-CSF, interferon- $\alpha$ , interferon- $\beta$ , EPO and Hemoglobin.

In accordance with this invention, when the embodiments of formula I-Ai, I-Aii, I-Aiii and I-Aiv are reacted with the proteins by reaction as shown in Scheme 1, the following compounds are produced.

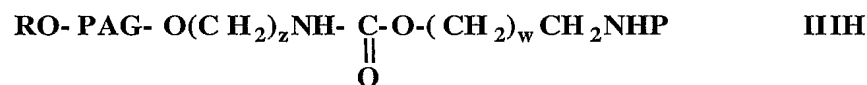
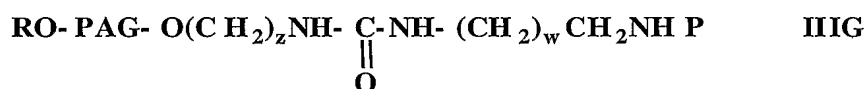
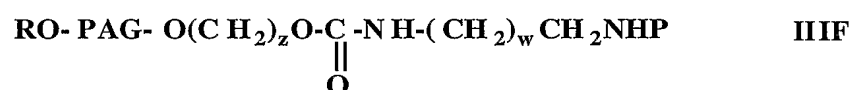
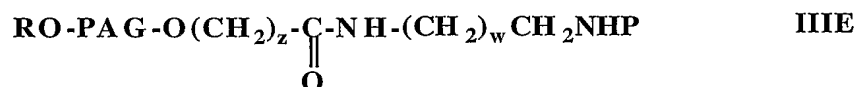

wherein P, R, PAG, z and w are as above.

The following examples are illustrative of the invention and are not to be construed as limiting the invention. In the following examples, the numbering as "1," etc. refers to the reaction scheme following the descriptive portions in each example.

### EXAMPLES

#### Example 1. Scheme A (Type I-Ai)

##### **Synthesis of mPEG-amide-propionaldehyde.**

Methoxy PEG-OH (M.W. 20,000, n=452) 1 and potassium t-butoxide were dissolved in t-butyl alcohol and stirred at 60°C. Ethyl bromoacetate was then slowly added and the mixture stirred for another 15 hours at 80-85°C. After filtering the reaction mixture, the solvent was evaporated under reduced pressure. The residue was dissolved in distilled water, washed with diethyl ether, and extracted twice with dichloromethane. The dichloromethane solution was dried over magnesium sulfate and the solvent removed under vacuum.

Precipitation was induced by the addition of diethyl ether to the crude residue and the precipitated compound was then filtered and dried under vacuum to give the product 2 as a white powder.

The mPEG-ethyl acetate was dissolved in 1 N-sodium hydroxide and stirred for 15  
5 hours at room temperature. The reaction mixture was then adjusted to pH 2 with 1 N aqueous HCl and extracted twice with dichloromethane. The extracted organic layer was dried over magnesium sulfate and the organic solvent removed. Diethyl ether was then added to the residue and the precipitated compound filtered. The product was dried under vacuum and the resulting acid 3 obtained as a white powder.

10 To a solution of the mPEG-acetic acid 3 dissolved in dichloromethane and cooled to 0-5°C, was added N-hydroxysuccinimide followed by a solution of dicyclohexylcarbodiimide in dichloromethane. The reaction mixture was stirred for 15 hours at room temperature. The by product, dicyclohexylurea, was removed from the reaction mixture by filtration and the residual organic solvent evaporated. The crude residue was then recrystallized from ethyl  
15 acetate filtered, washed twice with diethyl ether and dried for 12 hours under vacuum to afford the mPEG-succinimidyl acetate 4 as a white powder (see Example 2).

The mPEG-succinimidyl acetate 4 was dissolved in dichloromethane and stirred at room temperature while a solution of 1-amino-3, 3-diethoxypropane in dichloromethane was added. The resulting solution was then stirred for 2 hours at room temperature. Precipitation  
20 was induced by the addition of diethyl ether. The product was then filtered and recrystallized from ethyl acetate. The recrystallized compound was dried under vacuum to give 5 as a white powder.

The diethyl acetal 5 was dissolved in an aqueous solution containing phosphoric acid (pH1) and stirred for 2 hours at 40-50°C. After cooling the reaction mixture to room  
25 temperature, the acidity was reduced to a pH6 by the addition of a 5% aqueous sodium

bicarbonate solution. Brine was added and the resulting mixture extracted twice with dichloromethane. The organic layer was dried over magnesium sulfate, filtered and the solvent evaporated under reduced pressure. Precipitation was induced by the addition of diethyl ether to the crude residue. The product was collected and dried under vacuum to give

5 6 as a white powder.

By using the same procedure, compounds of the type I-Ai can be prepared whereby the integer n may be from 22 to 23,000.

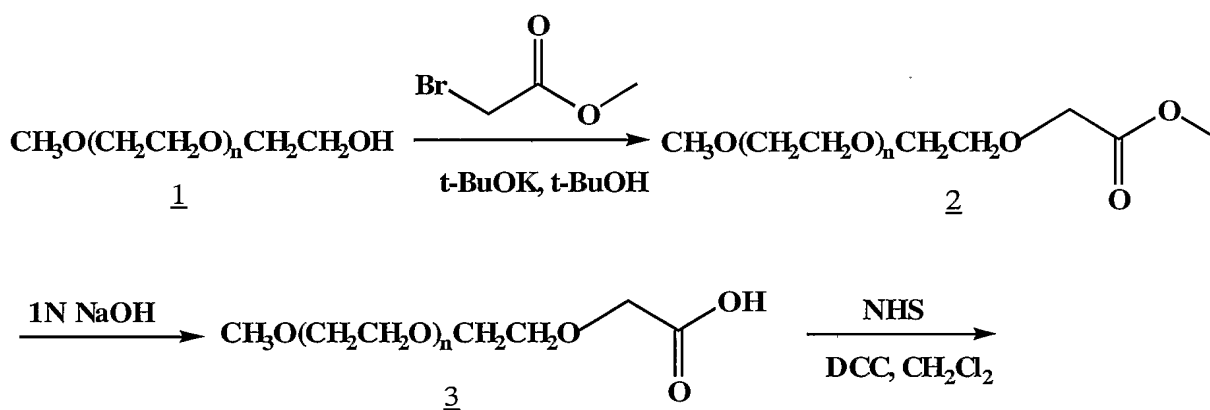

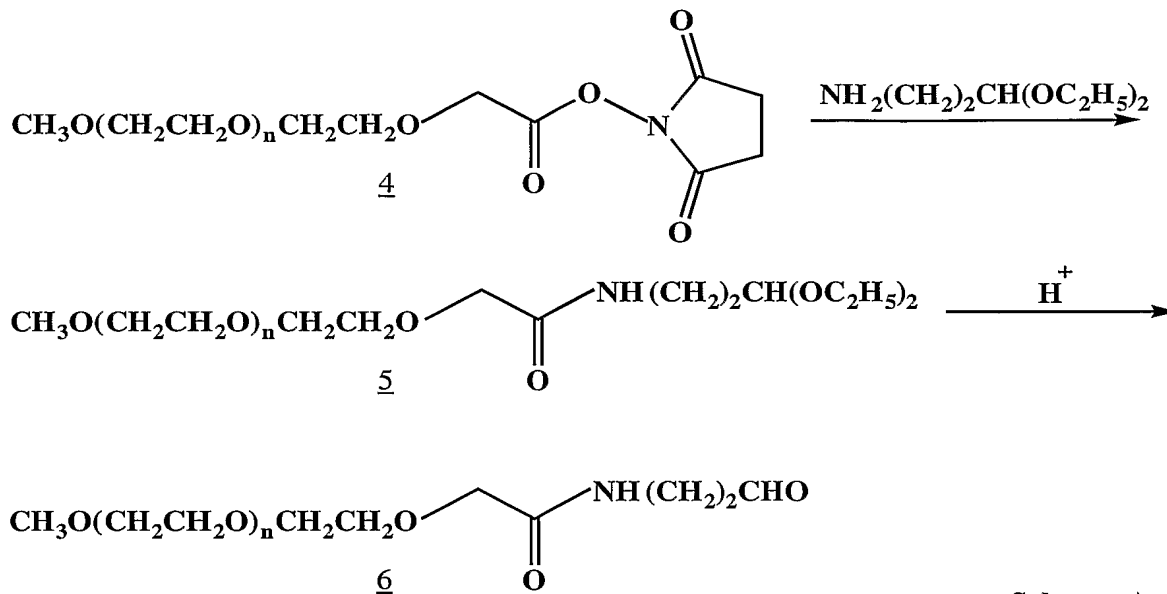

The integer n may be from 22 to 2,300 but more preferably 22 to 1,000.

**Example 2. Scheme B (Type I-Ai) Synthesis of mPEG-amide-butylaldehyde**

- To 10g, (1 mmol) of polyethylene glycol propionic acid 1, (MW 10,000, n=226) dissolved in dry methylene chloride (30 ml) was added dry and finely powdered NHS (0.56 g, 5mmol). The flask was cooled in an ice-water bath and DCC (0.22g, 1.08 mmol) added.
- 5 The reaction mixture was stirred at 0°C for 1 h and at room temperature for 24 h. The precipitated 1,3-dicyclohexylurea (DCU) was removed by filtration, and the filtrate added to ether (50 ml). After cooling to 4°C the crude material 2 was collected by filtration and purified by precipitating twice from methylene chloride by the addition of ether.
- 10 To the N-hydroxy succinate derivative 2 (8.5g, ~ 0.85 mmol) dissolved in dry methylene chloride (25 ml) there was added 1-amino-4,4-dimethoxybutane (0.33g, 2.5 mmol). The reaction mixture was stirred at room temperature for 2 h and the product precipitated in ether (100 ml). After cooling to 4°C the crude acetal of formula 3 was collected by filtration and precipitated twice from methylene chloride by addition of ether to obtain 8g of the acetal as a



white solid. The acetal was then dissolved in 50 ml of 0.1M HCL and stirred at room temperature for 4h to produce the amide aldehyde 4. The water was then removed under reduced pressure, and the crude amide-aldehyde product 4 was purified by chromatography.

By using the same procedure, compounds of the type I-Ai can be prepared whereby the

5 integer n may be from 22 to 23,000.

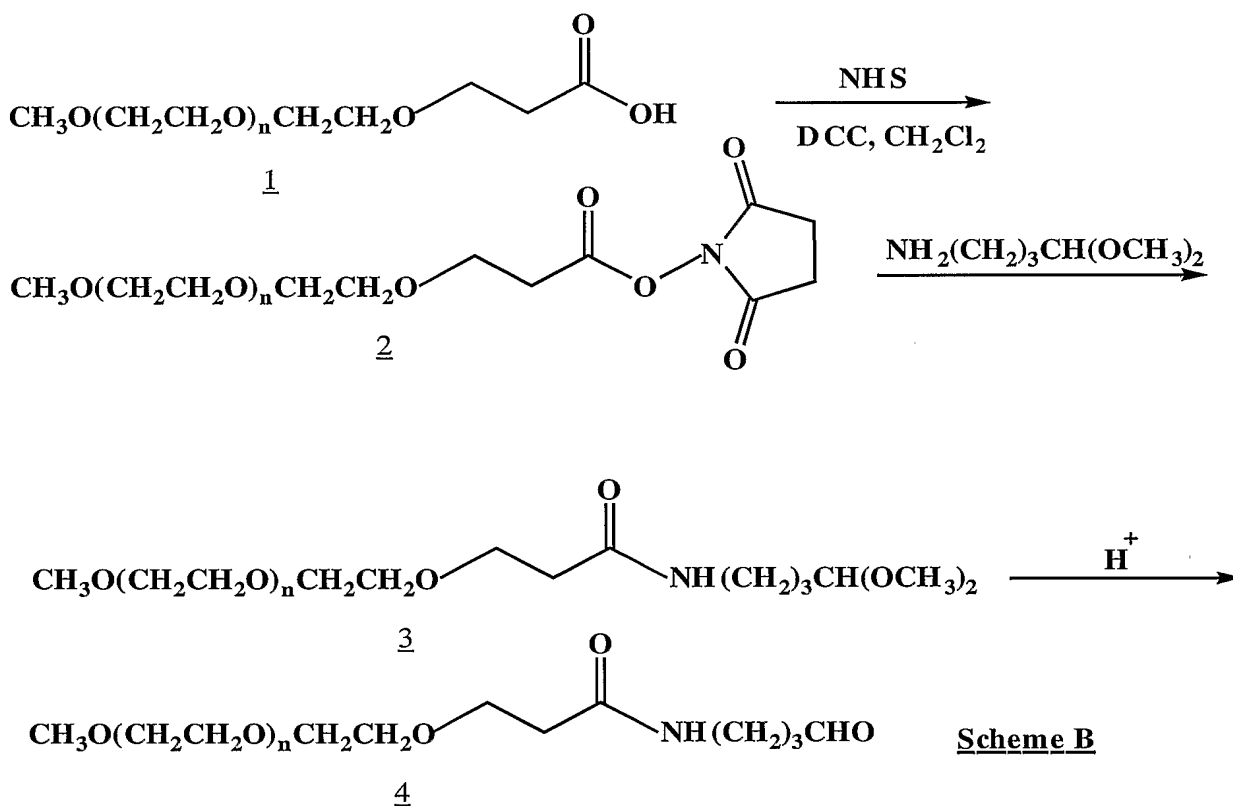

The integer n may be from 22 to 2,300 but more preferably 22 to 1,000.

### 10 Example 3. Scheme C (Type I-Aii)

#### Synthesis of mPEG-urethane-propionaldehyde.

Triphosgene (148mg, 0.5mmol) in 5ml of dichloromethane was added slowly to a solution of 10g of mPEG 1 (0.5mmol) (MW 20,000, n=452) dissolved in 30ml of dichloromethane and the resulting mixture stirred for 15 hours at room temperature. The

organic solvent was then removed under vacuum and the residue washed with dry ether and filtered. The acid chloride was then dissolved in 30ml of dry dichloromethane and treated with 80mg (0.7mmol) of N-hydroxysuccinimide followed by triethylamine (71mg, 0.1ml). After 3 hours, the solution was filtered and evaporated to dryness. The residue was dissolved in warm (50°C) ethyl acetate, and then the solution cooled to 0°C. The resulting precipitate 2 was collected as a white powder, and the product dried under vacuum.

To a solution of the 5g (0.25mmol) of mPEG-succinimidylcarbonate 2 dissolved in 30ml of dichloromethane was added 1-amino-3, 3-diethoxypropane (110mg, 0.75mmol). The reaction mixture was then stirred for 2 hours at room temperature. Ether was then added and the resulting precipitate collected and recrystallized from ethyl acetate. The product 3 which was washed twice with diethylether after filtration and dried under vacuum was obtained as a white powder.

The diethyl acetal 3 (5g) was dissolved in an aqueous solution containing phosphoric acid (pH1) and stirred for 2 hours at 40-50°C. After cooling the reaction mixture to room temperature, the acidity was reduced to a pH6 by the addition of a 5% aqueous sodium bicarbonate solution. Brine was added and the resulting mixture extracted twice with dichloromethane. The organic layer was dried over magnesium sulfate, filtered and the solvent evaporated under reduced pressure. Precipitation was induced by the addition of diethyl ether to the crude residue. The product was collected and dried under vacuum to give 4 as a white powder.

By using the same procedure, compounds of the type I-Aii can be prepared whereby the integer n may be from 22 to 23,000.

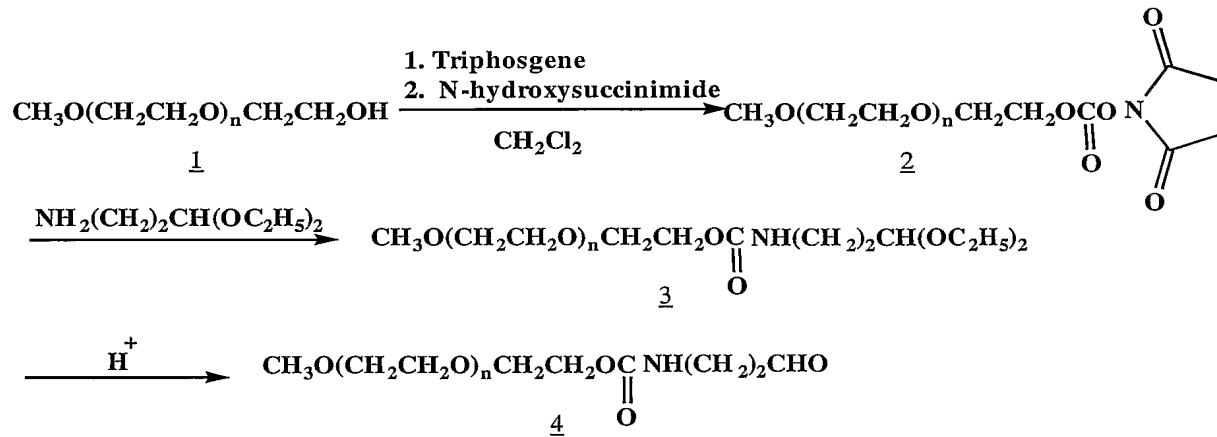
**Scheme C**

The integer n may be from 22 to 2,300 but more preferably 22 to 1,000.

**Example 4. Scheme D (Type I-Aii)****Synthesis of mPEG-urethane-butylaldehyde.**

To a solution of 201.6mg (1mmol) of 4-nitrophenyl chloroformate and 118.6mg (0.97 mmol) of 4-dimethylaminopyridine dissolved in 10ml of dry methylene chloride was added dropwise a solution of 9.7g (0.97mmol) of mPEG 1 (MW10,000, n=225) dissolved in 50ml of methylene chloride and stirred for 1h at room temperature. To the resulting solution of the 4-nitrophenyl carbonate derivative of formula 2, was then added 172.8mg (1.17mmol) of 1-amino-4,4-dimethoxybutane. Stirring was continued for 20h after which time the product 3 was precipitated by the addition of ether (100 ml).

After cooling to 4°C, the crude acetal of formula 3 was collected by filtration and precipitated twice from methylene chloride by addition of ether to obtain 8g of the acetal as a white solid. The acetal was then dissolved in 50 ml of 0.1M HCL and stirred at room temperature for 4h. The water was then removed under reduced pressure, and the crude urethane-aldehyde 4 purified by chromatography.

By using the same procedure, compounds of the type I-Aii can be prepared whereby the integer n may be from 22 to 23,000.

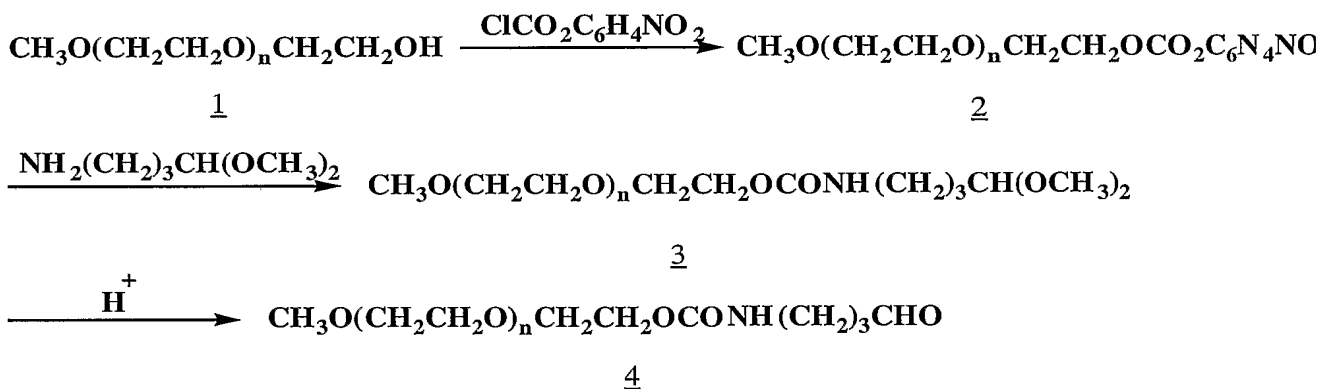
**Scheme D**

The integer n may be from 22 to 2,300 but more preferably 22 to 1,000.

**Example 5. Scheme E (Type I-Aiii)****Synthesis of mPEG-urea-propionaldehyde.**

To a solution of 2g (0.2mmol) of alpha-(2-aminoethyl)-omega-methoxypoly(oxyethanediyl)(MW 10,000, n=226) of formula 1 in 40 ml of dry methylene chloride, was added  
5 at 0°C, 65mg (0.3mmol) of di-2-pyridyl carbonate 2 and the mixture stirred for 5h. The product of formula 3 was then precipitated by the addition of 100ml of ether, filtered, and washed with an additional 100ml of ether. The product was then dried under vacuum under a slow stream of nitrogen to give 1.9g of the compound of formula 3 as a white powder. To the resulting urethane intermediate (1.5g, ~ 1.5mmol) dissolved in dry methylene chloride (25 ml)  
10 was added 0.6g (~4 mmol) of 1-amino-3,3-diethoxypropane. The reaction mixture was stirred at room temperature for 12 h and the acetal of formula 4 precipitated from ether (100 ml). After cooling to 4°C the crude acetal was collected by filtration and precipitated twice from methylene chloride by addition of ether to obtain 1.1g of the acetal as a white solid. The acetal was then dissolved in 50 ml of 0.1M HCL and stirred at room temperature for 4h. The  
15 water was then removed under reduced pressure, and the crude urea-aldehyde product of formula 5 was purified by chromatography.

By using the same procedure, compounds of the type I-Aiii can be prepared whereby the integer n may be from 22 to 23,000.

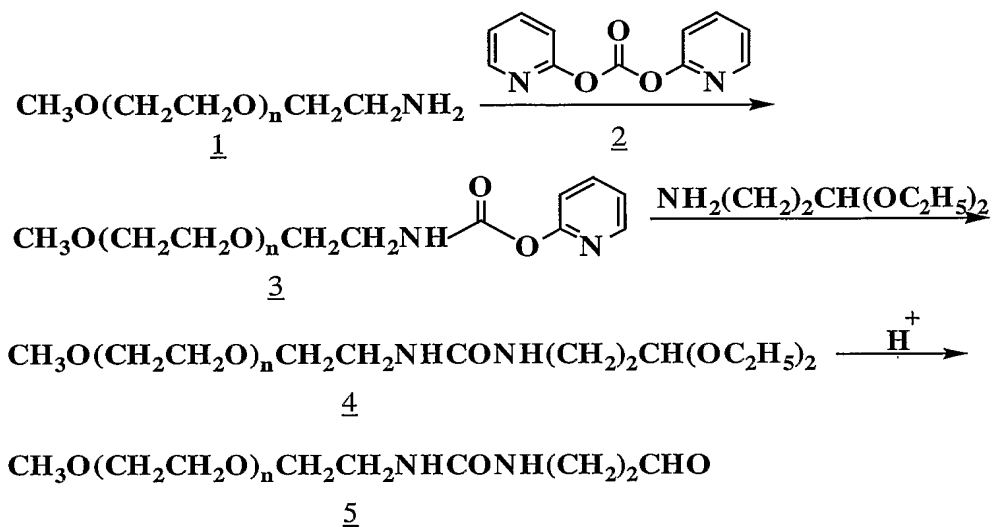
**Scheme E**

The integer n may be from 22 to 2,300 but more preferably 22 to 1,000.

**Example 6. Scheme F (Type I-Aiv)**

**5 Synthesis of mPEG-urethane-butylaldehyde.**

The pentane-1,2,5-triol of formula 1 (11.7g, 97.5 mmol) and toluene-p-sulfonic acid (0.3g) in acetone-light petroleum ether (bp 40-60 ) (1:1 60ml) were refluxed 24h with a Dean-Stark apparatus. The solvent was then removed under vacuum. The residue was then dissolved in ether and the ethereal solution washed with aqueous sodium carbonate, dried  
 10 (Na<sub>2</sub>CO<sub>3</sub>) and the ether removed. The resulting oil was then distilled to give 10.7g of the 1,3-dioxolane-2,2-dimethyl-4-propanol of formula 2 bp. 117-118, 12mm.(Golding et al., (1978) J.C.S. Perkin II, 839).

To a solution of 11.2g (55 mmol) of 4-nitrophenyl chloroformate in 100ml of acetonitrile was added slowly 7.3g (60 mmol) of 4-dimethylaminopyridine followed by 8g  
 15 (50 mmol) of the above acetonide product 2 dissolved in 20ml of acetonitrile. After stirring for 24h, the precipitated pyridinium hydrochloride was filtered and the solvent removed under reduced pressure. The residue was then dissolved in 200ml of ether and washed with a

5% aqueous solution of sodium bicarbonate. The ether solution was then dried ( $\text{Na}_2\text{CO}_3$ ) and the solvent removed under vacuum to give 16g of the acetonide of formula 3.

To a solution of 6g (0.6mmol) of alpha-(2-aminoethyl)-omega-methoxypoly(oxy-ethanediyl) (MW 10,000,n=226) of formula 4 in 40 ml of dry methylene chloride, was added at 0°C, 196mg (0.6mmol) of the 4-nitrophenyl carbonate of formula 3 and 74mg of 4-dimethylaminopyridine. The solution was stirred for 24h after which time the compound of formula 5 was precipitated by the addition of 150ml of ether. This product was filtered and further washed with ether to give 5g of the urethane-acetonide of formula 5 as a white solid.

The above urethane-acetonide of formula 5 (5g, 0.5mmol) was dissolved in 75ml of 0.1M HCl and stirred for 6h. The water and HCl were then removed under reduced pressure to give the corresponding diol product. To 5g of the diol dissolved in 75ml water was added 267mg of  $\text{NaIO}_4$  (1.25mmol) and the reaction allowed to proceed for 5h in the dark. The aldehyde of formula 6 was then isolated by size exclusion chromatography on a Sephadex G 10 column. Oxidation of the 1,2-diol may also be realized using  $\text{NaIO}_4$  supported on wet silica gel. Using this procedure the aldehyde is obtained without hydrate formation. (see Vo-Quang et al., (1989) Synthesis No.1,64).

By using the same procedure, compounds of the type I-Aiv can be prepared whereby the integer n may be from 22 to 23,000.

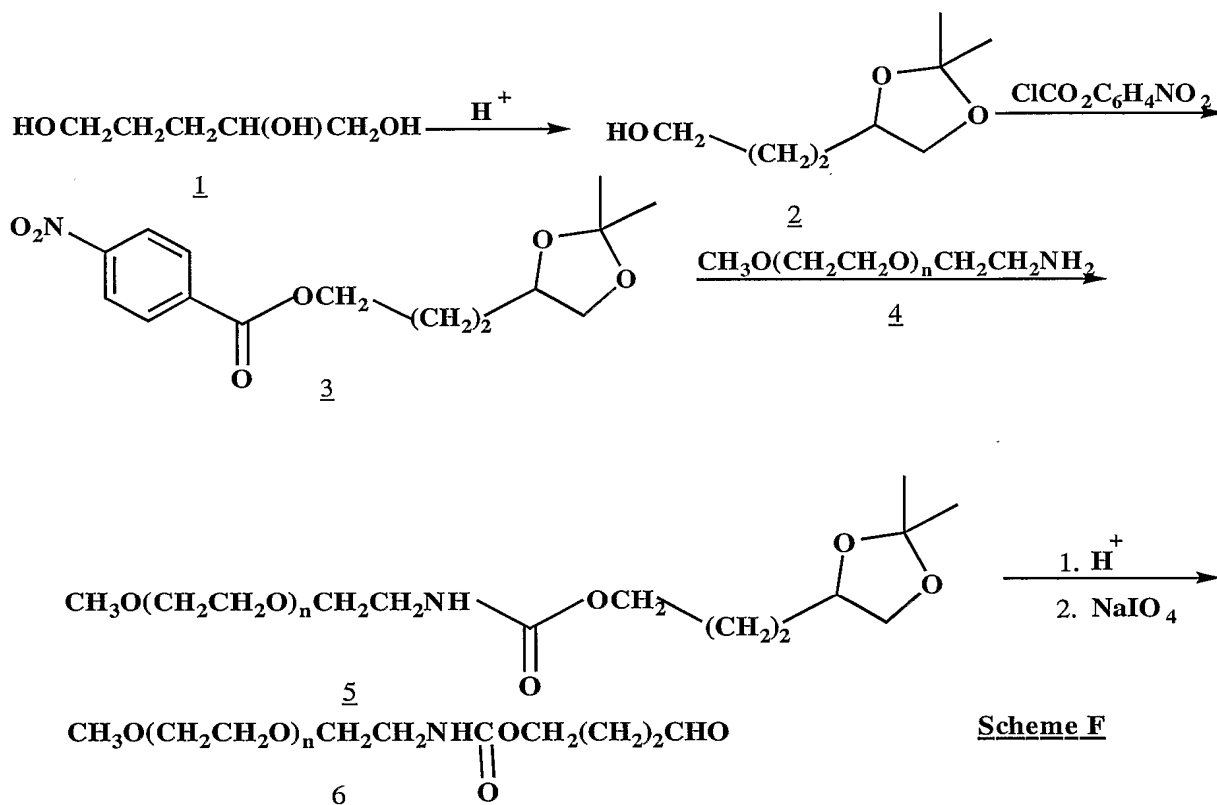

The integer n may be from 22 to 2,300 but more preferably 22 to 1,000.

### 5 Example 7. Scheme G (Type IB)

#### Synthesis of Pendant mPEG-urethane-propionaldehyde.

Nonane was added to a reaction vessel containing mPEG (M.W. 20,000), PEG (M.W. 20,000), or a dim-PEG and heated to 140-145°C. When the solid melted, acrylic acid and t-butyl peroxybenzoate (a reaction initiator) were slowly added to the reaction mixture over a period of 1.5 hours. After the addition, the mixture was stirred for an additional hour at 140-145°C. After the removal of residual nonane from the reaction mixture by evaporation, methanol was added to the mixture and heated and stirred until a homogeneous solution was obtained. The hot solution was then filtered under vacuum and the filtrate



diluted with a 90/10/ v/v MeOH/H<sub>2</sub>O solution. The resulting mixture was then filtered through a Pall Filtron ultrafiltration system and the filtrate then concentrated under reduced pressure. The residue was dissolved by heating with a 50/50 v/v acetone/isopropyl alcohol solution, cooled to room temperature, and placed in the refrigerator overnight. The product 1 was then filtered, washed 3 times with 50/50 v/v acetone/isopropyl alcohol solution and finally 3 times with diethyl ether and then vacuum dried overnight. The acid number of the pendant-PEG-propionic acid 1 was determined (mg of KOH needed to neutralize one gram of sample).

The pendant-PEG-propionic acid 1 was dissolved in dichloromethane and cooled to 0-5°C. N-hydroxysuccinimide was then added followed by the addition of dicyclohexylcarbodiimide dissolved in chloromethane. After stirring for 15 hours at room temperature, the dicyclohexylurea by product was removed from the reaction mixture via filtration and the residual organic solvent evaporated under vacuum (see Example 2). The crude residue was recrystallized from ethyl acetate, filtered, washed twice with diethyl ether, and dried for 12 hours under vacuum to give the pendant PEG-succinimidyl propionate 2 as a white powder.

To a solution of the pendant PEG-succinimidyl propionate 2 dissolved in dichloromethane was added at room temperature 1-amino-3, 3-diethoxypropane and the resulting solution stirred for 2 hours. Precipitation was induced by the addition of diethyl ether and the product so obtained recrystallized from ethyl acetate. The recrystallized compound was filtered, washed twice with diethyl ether, dried for 12 hours under vacuum to give the pendant-PEG-propionaldehyde diethyl acetal 3 as a white powder.

The pendant-PEG-propionaldehyde diethyl acetal 3 was dissolved in an aqueous solution containing phosphoric acid (pH 1) and stirred for 2 hours at 40-50°C. After cooling the reaction mixture to room temperature, the acidity was reduced to a pH6 by the addition of

a 5% aqueous sodium bicarbonate solution. Brine was added and the resulting mixture extracted twice with dichloromethane. The organic layer was dried over magnesium sulfate, filtered and the solvent evaporated under reduced pressure. Precipitation was induced by the addition of diethyl ether to the crude residue. The product was collected and dried under vacuum to give the pendant PEG-amide propionaldehyde 4 as a white powder.

By using the same procedure, compounds of the type IB can be prepared whereby the integer m may be from 22 to 23,000.

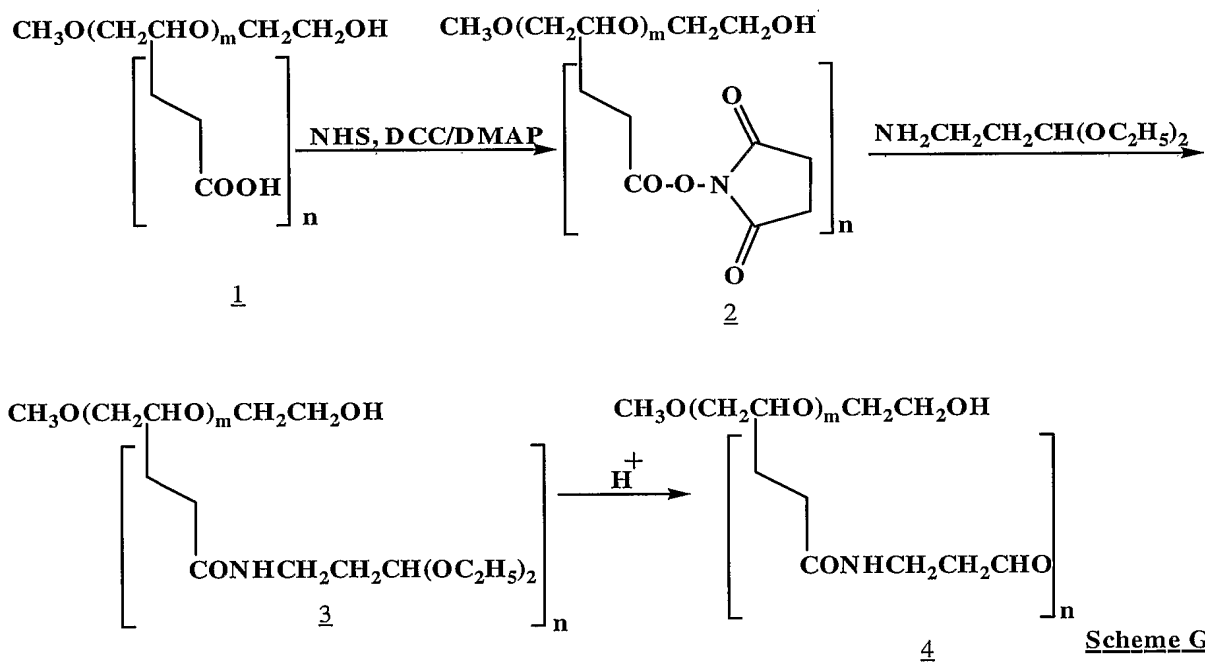

Scheme G

10

The integer m may be from 22 to 2,300 but more preferably 22 to 1,000.

The integer n may be 1 to 20 and more preferably 1 to 5.

#### Example 8. Scheme H (Type IC)

15 **Synthesis of Branched mPEG-amide-propionaldehyde.**

The conversion of the branched chain carboxy acid 1 to the corresponding propionaldehyde 2 was carried out as described in Example 7.

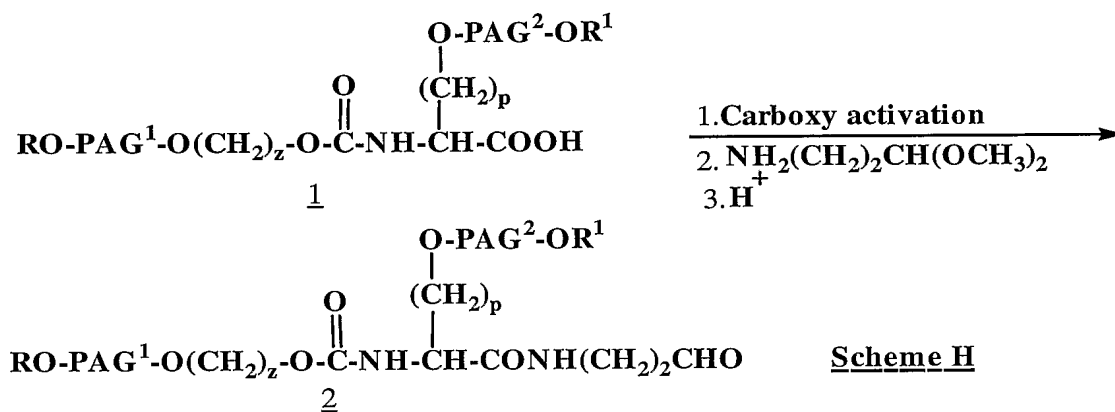

wherein R, R<sup>1</sup>, PAG<sup>1</sup>, PAG<sup>2</sup>, p and z are as above.

5

#### Example 9. Scheme I (Type IC)

#### Synthesis of Branched mPEG-amide-butylaldehyde.

The conversion of the branched chain carboxy acid 1 to the corresponding butylaldehyde 2 was carried out as described in Example 2.

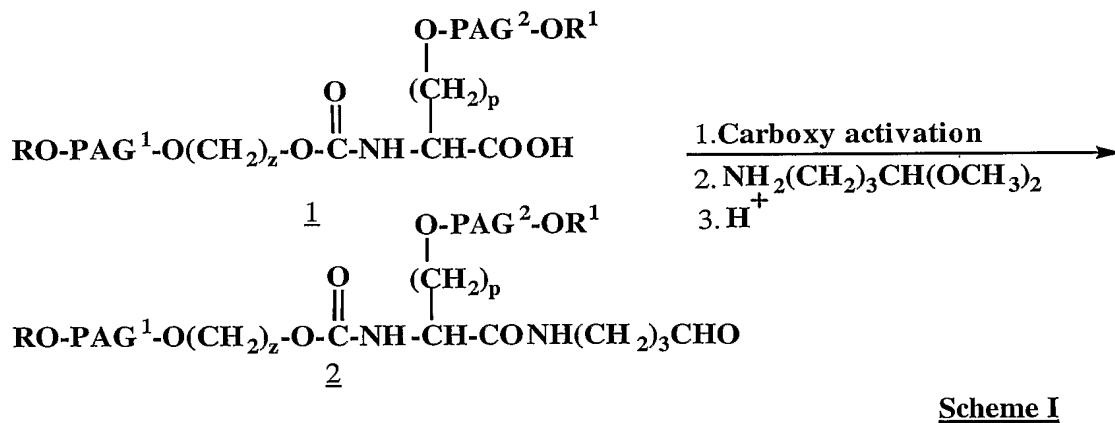

10

wherein R, R<sup>1</sup>, PAG<sup>1</sup>, PAG<sup>2</sup>, p and z are as above.

**Example 10. Scheme J (Type ID)****Synthesis of mPEG-Butyraldehyde.**

The pentane-1,2,5-triol of formula 1 (11.7g, 97.5 mmol) and toluene-p-sulfonic acid (0.3g) in acetone-light petroleum ether (bp 40-60 ) (1:1 60ml) refluxed 24h with a Dean-Stark  
5 apparatus. The solvent was then removed under vacuum. The residue was then dissolved in ether and the ethereal solution washed with aqueous sodium carbonate, dried (Na<sub>2</sub>CO<sub>3</sub>) and the ether removed. The resulting oil was then distilled to give 10.7g of 1,3 dioxolane-2,2-dimethyl-4-propanol of formula 2 bp. 117-118, 12mm.(Golding et al., (1978) J.C.S. Perkin II, 839).

10 To a solution of 6g (0.6mmol) of mPEG alcohol (MW 10,000, n=226) of formula 3 in 40 ml of dry methylene chloride, was added at -10°C, 182mg (0.26ml) of trimethylamine and toluene-p-sulfonyl chloride (381mg, 2mmol). The cooling was removed and the mixture stirred at room temperature for 18h. The product was precipitated by the addition of 150ml of ether, filtered and further washed with ether to give 5g of the compound of formula 4 as a  
15 white solid.

A solution of 64mg (0.4mmol) of 1,3-dioxolane-2,2-dimethyl-4-propanol 2 dissolved in 10ml of dry benzene was added dropwise under nitrogen to a mixture of 20mg of sodium hydride suspended in 5ml of benzene. The mixture was then stirred for 30min to give the sodium alkoxide salt 2a. To this solution was then added dropwise over a 20-min period, a  
20 solution of 4g (0.4mmol) of the PEG tosylate 4 dissolved in 30 ml of methylene chloride. The reaction mixture was then stirred for 24h at 40 C and then added dropwise to 150ml of ether to precipitate the compound of formula 5 as a white solid. This material was then purified by chromatography on a small alumina column.

The PEG acetamide 5 (3.5g) was dissolved in 40ml of 0.1M HCl and stirred for 6h.  
25 The water and HCl were then removed under reduced pressure to give the corresponding diol

product. To 3g of the 1,2-diol dissolved in 40ml water (~0.3mmol of diol) was added 160mg of NaIO<sub>4</sub> (0.75mmol) and the reaction allowed to proceed for 5h in the dark to produce the compound of formula 6 which was isolated by size exclusion chromatography on a Sephadex G 10 column.

- 5 By using the same procedure, compounds of the type ID can be prepared whereby the integer m may be from 22 to 23,000.

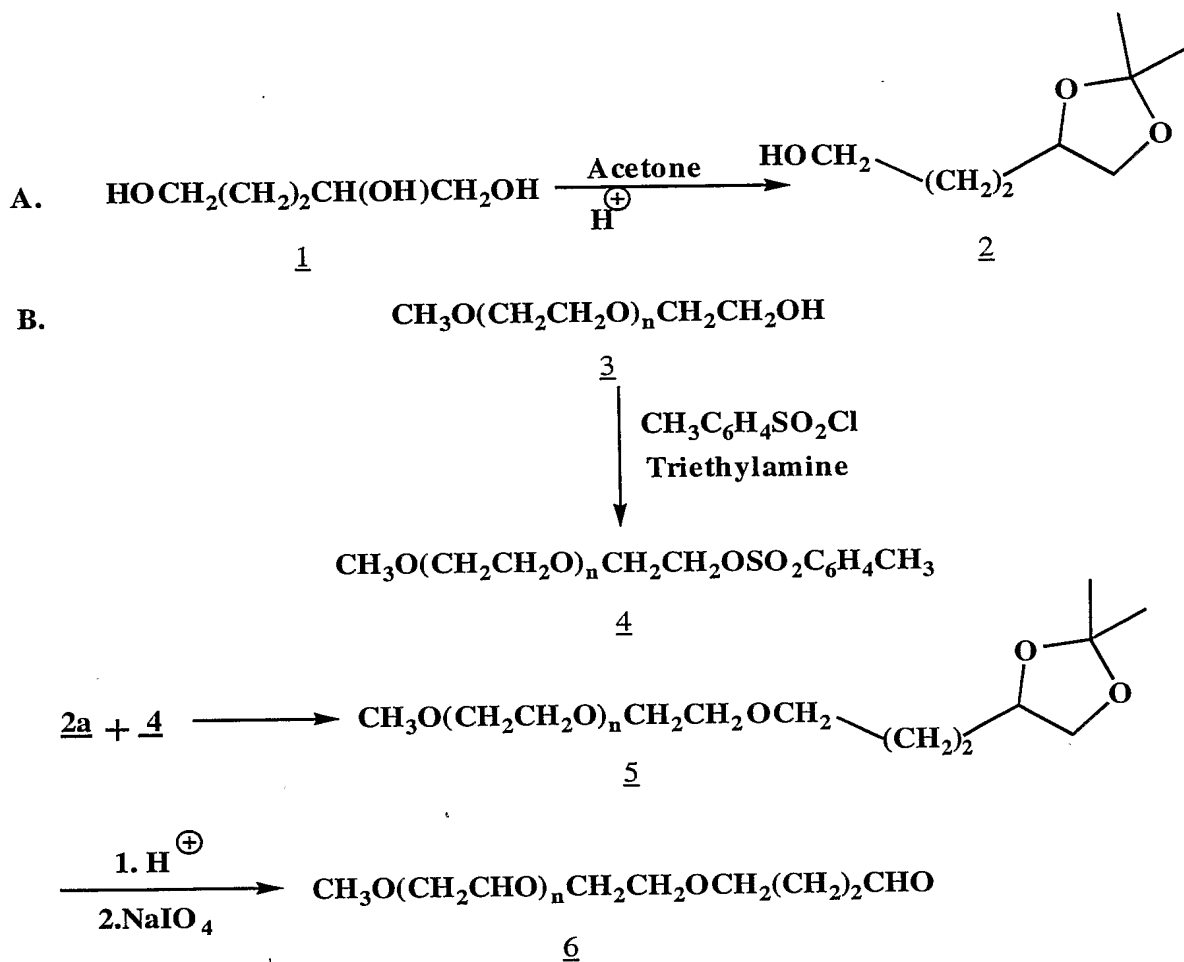

**Scheme J**

The integer n may be from 22 to 2,300 but more preferably 22 to 1,000.

**What is Claimed:**

1. An aldehyde having the formula:

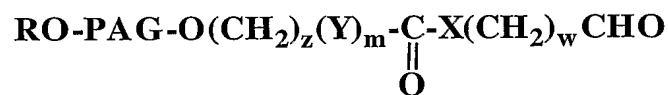

IA

5 wherein R is hydrogen or lower alkyl; X and Y are individually  
 selected from -O - or - NH- with the proviso that X is NH  
 when m is 1 and Y is -O-; PAG is a divalent residue of  
 polyalkylene glycol resulting from removal of the terminal  
 hydroxy groups and having a molecular weight of from about  
 1,000 to about 100,000 Daltons ; z is an integer of from 2 to 4,  
 10 m is an integer of from 0 to 1; and w is an integer of from 2 to  
 8, wherein the aldehyde group is free or protected with a  
 hydrolyzable aldehyde protecting group, or a hydrate thereof.

2. The aldehyde of claim 1 wherein said residue is formed from polyethylene glycol.  
 3. The aldehyde of claim 2 wherein the residue has a molecular weight of  
 15 5,000 to 50,000 Daltons.  
 4. The aldehyde of claim 1 wherein said aldehyde has a formula:

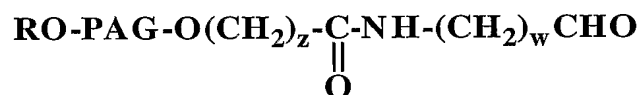

I-Ai

wherein R, PAG, z and w are as above.

- 20 5. The aldehyde of claim 4 wherein said divalent residue is polyethylene glycol.  
 6. The aldehyde of claim 5 wherein the residue has a molecular weight of 5,000 to  
 50,000 Daltons.

7. The aldehyde of claim 6 wherein R is methyl and the molecular weight of the residue is about 10,000 Daltons.

8. The aldehyde of claim 6 wherein R is methyl, and the molecule weight of the residue is 20,000 Daltons.

5 9. The aldehyde of claim 1 wherein said aldehyde has the formula:

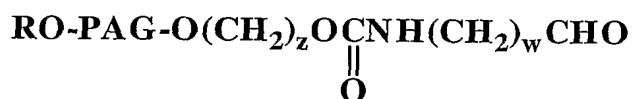

wherein R, PAG, z and w are as above.

**I-Aii.**

10. The aldehyde of claim 9 wherein said divalent residue is formed from polyethylene glycol.

10 11. The aldehyde of claim 10 wherein the residue has a molecular weight of 5,000 to 50,000 Daltons.

12. The aldehyde of claim 11 wherein R is methyl and said residue has a molecular weight of 10,000 Daltons.

13. The aldehyde of claim 1 having the formula:



15

wherein R, PAG, z and w are as above.

**I-Aiii**

14. The aldehyde of claim 13 wherein said divalent residue is polyethylene glycol.



15. The aldehyde of claim 14 wherein the residue has a molecular weight of 5,000 to 50,000 Daltons.

16. The aldehyde of claim 15 wherein R is methyl and the molecular weight of the residue is 10,000 Daltons.

5 17. The aldehyde of claim 1 having the formula:

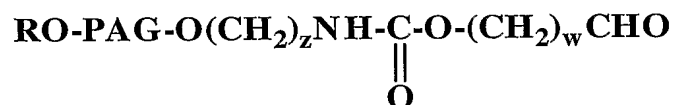

wherein R, PAG, z and w are as above.

I-Aiv

18. The aldehyde of claim 17 wherein said divalent residue is formed from polyethylene glycol.

10 19. The compound of claim 18 wherein the residue has a molecular weight of 5,000 to 50,000 Daltons.

20. The aldehyde of claim 19 wherein R is methyl and the molecular weight of the residue is 10,000 Daltons.

21. An aldehyde of the formula:

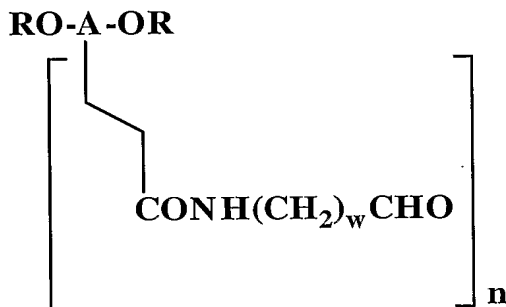

15

**IB**

wherein R is hydroxyl or lower alkyl; A is a polyethylene glycol residue with its two terminal hydroxy groups being

20

removed having a molecular weight of from 1,000 to 100,000

Daltons and having a valence of from 1 to 5; n is an integer of from 1 to 5 which integer is the same as the valence of A; and w is an integer from 2 to 8.

22. The aldehyde of claim 21 wherein A is a residue having a molecular weight of from 5,000 to 50,000 Daltons.
23. The aldehyde of claim 22 where n is 1.
24. The aldehyde of claim 23 where the R is methyl and A has a molecular weight of about 20,000 Daltons.
25. The aldehyde of claim 24 wherein R is methyl and A has a molecular weight of 10,000 Daltons.
26. An aldehyde of the formula:

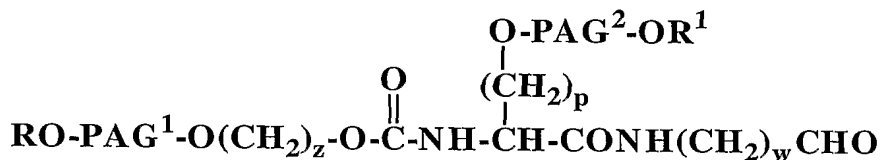

IC

- 15 wherein PAG<sup>1</sup> and PAG<sup>2</sup> are independently divalent residues of poly lower alkylene glycol resulting from removal of the two terminal hydroxy groups with the PAG<sup>1</sup> and PAG<sup>2</sup> residues having a combined molecular weight of from 1,000 to 100,000 Daltons; R and R<sup>1</sup> are individually lower alkyl or hydrogen and
- 20 w is an integer from 2 to 8; p is an integer of from 1 to 5; z is an integer of from 2 to 4, wherein the aldehyde group is hydrated, free or protected by a hydrolyzable aldehyde protecting group.

27. The aldehyde of claim 26 wherein said R is methyl,  $\text{PAG}^1$  and  $\text{PAG}^2$  are formed from polyethylene glycol residues.

28. The aldehyde of claim 27 wherein R is methyl and  $\text{PAG}^1$  and  $\text{PAG}^2$  both have a molecular weight of 5,000 to 50,000 Daltons.

5 29. A compound of the formula:

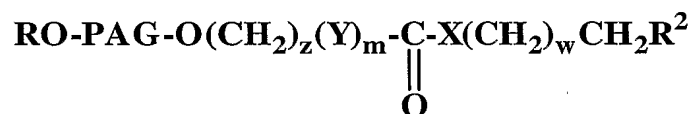

wherein R is hydrogen or lower alkyl;  $\text{R}^2$  is  $\text{CH}(\text{OH})\text{CH}_2\text{OH}$ , X and Y are individually selected from -O- or -NH- with the proviso that X is NH when m is 1 and Y is -O-; PAG is a divalent residue of polyalkylene glycol resulting from removal of the terminal hydroxy groups and having a molecular weight of from about 1,000 to about 100,000 Daltons ; z is an integer of from 2 to 4, m is an integer of from 0 to 1; and w is an integer of from 2 to 8.

15 30. A compound of the formula:

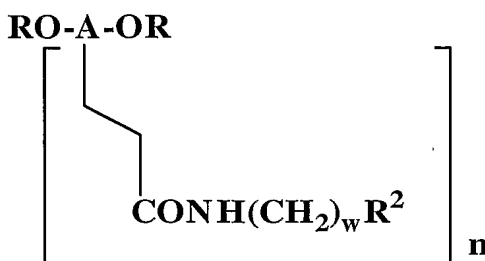

wherein R is hydrogen or lower alkyl,  $\text{R}^2$  is  $\text{CH}(\text{OH})\text{CH}_2\text{OH}$ , A is a polyethylene glycol residue with its two terminal hydroxy groups being removed having a molecular weight of from 1,000

to 100,000 Daltons and having a valence of from 1 to 5; n is an integer of from 1 to 5 which integer is the same as the valence of A; and w is as integer for 2 and 8.

31. A compound of the formula:

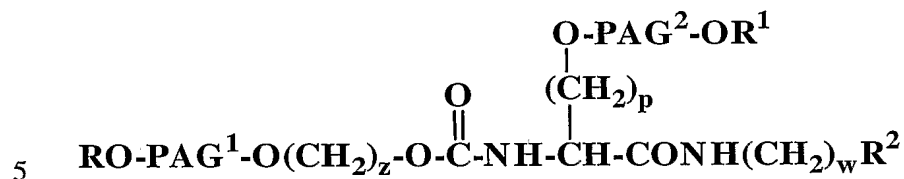

wherein  $\text{PAG}^1$  and  $\text{PAG}^2$  are independently divalent residues of poly lower alkylene glycol resulting from removal of the two terminal hydroxy groups with the  $\text{PAG}^1$  and  $\text{PAG}^2$  residues having a combined molecular weight of from 1,000 to 100,000 Daltons; R and  $\text{R}^1$  are individually lower alkyl or hydrogen,  $\text{R}^2$  is  $-\text{CH}(\text{OH})\text{CH}_2\text{OH}$ , w is an integer from 2 to 8; p is an integer of from 1 to 5, and z is an integer of from 2 to 4.

32. A compound of the formula:

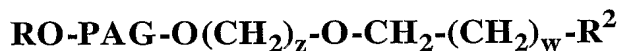

wherein R is lower alkyl or hydrogen,  $\text{R}^2$  is  $\text{CH}(\text{OH})\text{CH}_2\text{OH}$ , PAG is the divalent residue of polyethylene glycol resulting from removal of the two terminal hydroxy groups having a molecular weight of from 1,000 to 100,000 Daltons, z is a integer of from 2 to 4 and w is an integer of from 2 to 8.

33. A conjugate of the formula:

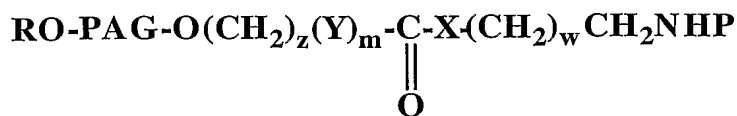

III-A

wherein P is the residue of a protein with its amino group removed, R is hydrogen or lower alkyl; X and Y are individually selected from -O- or -NH with the proviso that X is NH when Y is -O-; PAG is a divalent residue of polyalkylene glycol resulting from removal of the terminal hydroxy groups, having a molecular weight of from 1,000 to 100,000 Daltons ; z is an integer of from 2 to 4, m is an integer of from 0 to 1; and w is an integer of from 2 to 8.

34. The conjugate of claim 33 where said conjugate has the formula:

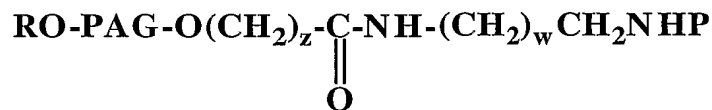

10

wherein P, R, PAG, z and w are as above.

**III-E**

35. The conjugate of claim 34 wherein PAG is formed from polyethylene glycol having a molecular weight of from 5,000 to 50,000.

36. The conjugate of claim 35 where said P is G-CSF, EPO, IFN- $\alpha$ , IFN- $\beta$  or Hemoglobin.

15

37. The conjugate of claim 33 wherein said conjugate has the formula:

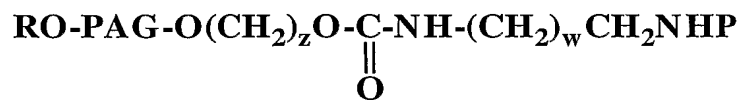
**III-F**

wherein P, R, PAG, z and w are as above.

38. The conjugate of claim 37 wherein PAG is polyethylene glycol having a molecular weight of from 5,000 to 50,000.

20

39. The conjugate of claim 38 where said P is G-CSF, EPO, IFN- $\alpha$ , IFN- $\beta$  or Hemoglobin.

40. The conjugate of claim 33 wherein said conjugate has the formula:

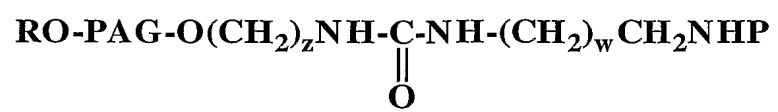

wherein P, R, PAG, z and w are above.

**III-G**

41. The conjugate of claim 40 wherein PAG is polyethylene glycol having a molecular weight of from 5,000 to 50,000.

42. The conjugate of claim 41 where said P is G-CSF, EPO, IFN- $\alpha$ , IFN- $\beta$  or Hemoglobin.

5 43. The conjugate of claim 33 wherein said conjugate has the formula:

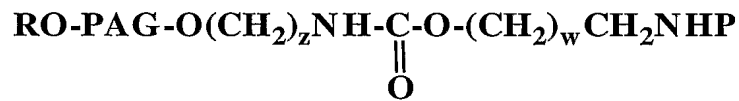

wherein P, R, PAG, z and w are as above. **III-H**

44. The conjugate of claim 43 wherein PAG is polyethylene glycol having a molecular weight of from 5,000 to 50,000 Daltons.

10 45. The conjugate of claim 44 where said P is G-CSF, EPO, IFN- $\alpha$ , IFN- $\beta$  or Hemoglobin.

46. A conjugate of the formula:

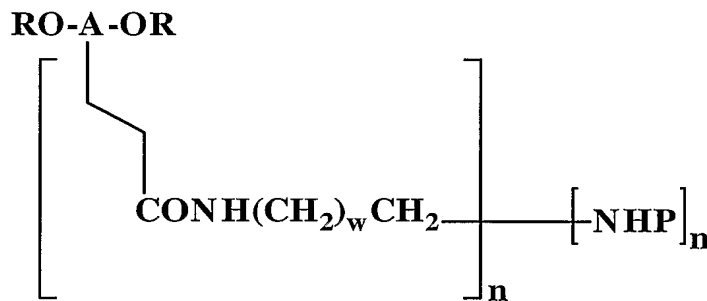

**III-B**

15 wherein P is a residue of a protein with its amino group removed, R is hydrogen or lower alkyl, A is a polyethylene glycol residue with its two terminal hydroxy groups being removed having a molecular weight of from 1,000 to 100,000 Daltons and having a valence of from 1 to 5; n is an integer of  
 20 from 1 to 5 which integer is the same as the valence of A, and

which integer is the same as the number of proteins P, w is as above.

47. The conjugate of claim 46 where n is 1.
48. The conjugate of claim 46 where A is polyethylene glycol residue.
- 5 49. The conjugate of claim 48 wherein PAG is polyethylene glycol having a molecular weight of from 5 to 50,000 Daltons.
50. A conjugate with the formula:

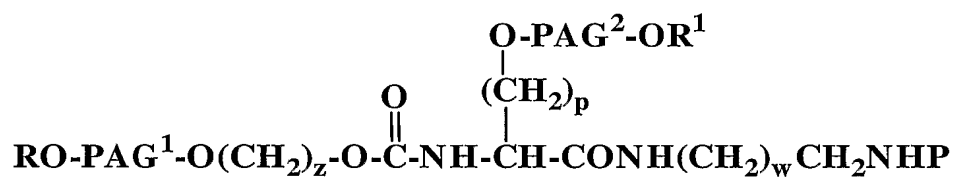

**III-C**

- 10 wherein P is a residue of a protein with its amino group being removed, PAG<sup>1</sup> and PAG<sup>2</sup> are independently divalent residues of poly lower alkylene glycol resulting from removal of the two terminal hydroxy groups and with the PAG<sup>1</sup> and PAG<sup>2</sup> residues having a combined molecular weight of from 1,000 to 100,000
- 15 Daltons; R and R<sup>1</sup> are individually lower alkyl or hydrogen, w is an integer of from 2 to 8, p is an integer of from 1 to 5, and z is an integer of from 2 to 4.

51. The conjugate of claim 50 where PAG<sup>1</sup> and PAG<sup>2</sup> are each polyethylene glycol having a combined molecular weight from 5,000 to 50,000.



52. A conjugate of the formula

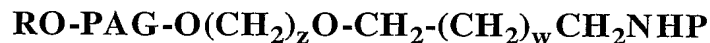

### III-D

5 wherein P is a residue of a protein with an amino group being removed, PAG is a divalent residue of a poly lower alkylene glycol resulting from removal of the two terminal hydroxy groups having a molecular weight of from 1,000 to 100,000 Daltons, R is lower alkyl or hydrogen, w is an integer from 2 to 8 and z is an integer from 2 to 4.

10 53. The conjugate of claim 52 where PAG is a polyethylene glycol residue.

54. The conjugate of claim 53 where PAG has a molecular weight of from 5,000 to 50,000 Daltons.

55. A process for producing an aldehyde of the formula:

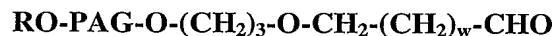

15 wherein R is lower alkyl, PAG is a divalent residue of polyalkylene glycol resulting from removal of the terminal hydroxy groups, having a molecular weight of from 1,000 to 100,000 Daltons ; z is an integer of from 2 to 4, and w is an integer of from 2 to 8;

20 from a hydroxy compound of the formula

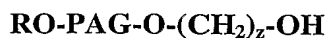

wherein 3, R, PAG and z are as above

comprising esterifying said hydroxy compound to form an ester of the formula

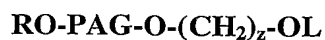

wherein R and PAG are as above,

by reacting said hydroxy compound with a sulfonating agent having the formula:



wherein L is a sulfonate leaving group and Halo is a halogen,

5 to form said sulfonate ester, and reacting said ester with an acetonide of the formula:

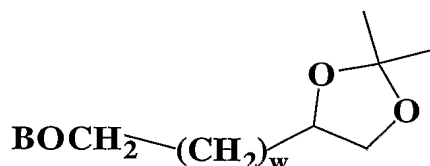

wherein w is as above and B is an alkali metal

to form a polymeric acetonide of the formula

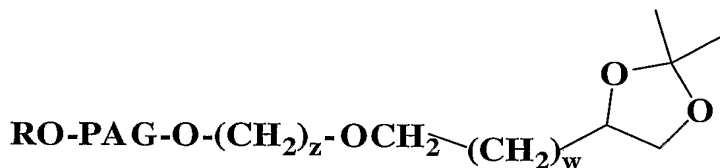

10

wherein R, P, PAG, z and w are as above

and thereafter hydrolyzing said polymeric acetonide under acid conditions to remove the acetonide group, and thereafter subjecting said hydrolyzed acetonide to oxidation with a periodate oxidizing agent to form said aldehyde.

15 56. A process for producing an aldehyde of the formula:

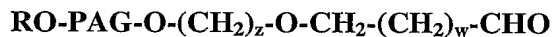

wherein R is lower alkyl, PAG is a divalent residue of polyalkylene glycol resulting from removal of the terminal hydroxy groups, having a molecular weight of from 1,000 to 100,000 Daltons ; z is an integer of from 2 to 4, and w is an integer of from 2 to 8;

20

from a hydroxy compound of the formula

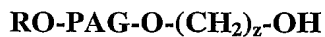

wherein R, PAG and z are as above

comprising halogenating said hydroxy compound to form a halide of the formula



by reacting said hydroxy compound with a halogenating agent having the formula:



wherein X is a halogen,

to form said halide, and reacting said halide with an acetonide of the formula:

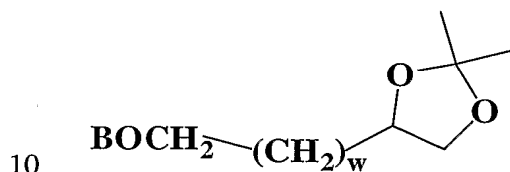

wherein w is as above and B is an alkali metal

to form a polymeric acetonide of the formula

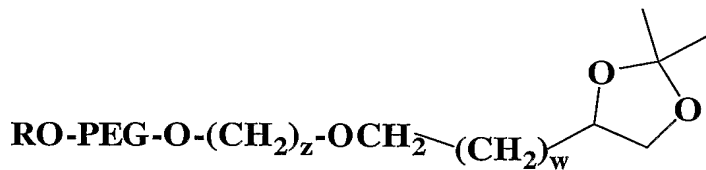

wherein R, PAG, z and w are as above

15 and thereafter hydrolyzing said polymeric acetonide under acid conditions to remove the acetonide group, and thereafter subjecting said hydrolyzed acetonide to oxidation with a periodate oxidizing agent to form said aldehyde.

57. A process for producing an aldehyde of the formula:

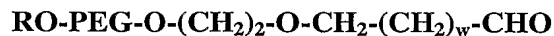

20 wherein PEG is a divalent residue of polyethylene glycol resulting from removal of the terminal hydroxy groups, having

a molecular weight of from 1,000 to 100,000 Daltons ; and w is  
an integer of from 2 to 8;

from an acetonide of the formula

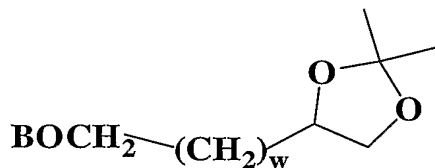

5                    wherein B is an alkali metal, and w is as above

comprising reacting said acetonide with ethylene oxide by passing liquid ethylene oxide into  
an organic solution containing the acetonide under polymerization conditions to form the  
hydroxy acetonide compound of the formula.

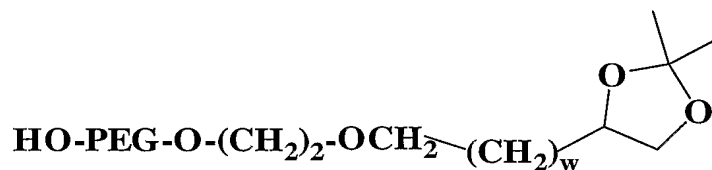

10                   wherein PEG and w are as above,

etherifying said hydroxy acetonide with a lower alkyl halide to form a polymeric acetonide of  
the formula

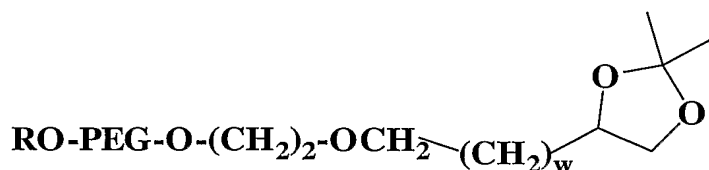

15                   wherein PEG, R and w are as above,

and thereafter hydrolyzing said polymeric acetonide under acid conditions to remove the  
acetonide group, and thereafter subjecting said hydrolyzed acetonide to oxidation with a  
periodate oxidizing agent to form said aldehyde.

58.    A process for producing an aldehyde of the formula

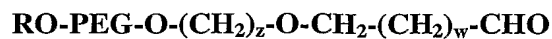

wherein PEG is a divalent residue of polyethylene glycol  
 resulting from removal of the terminal hydroxy groups, having  
 a molecular weight of from 1,000 to 100,000 Daltons ; z is an  
 5 integer of from 2 to 4, and w is an integer of from 2 to 8,  
 preferably 2 to 4;

from a polymeric acetonide of the formula

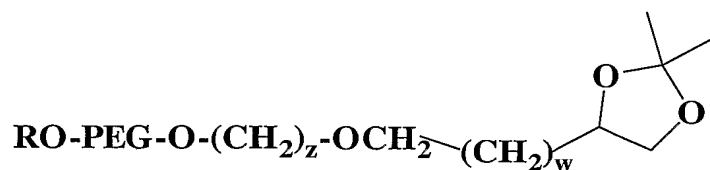

wherein PEG, R, w and z are as above.

- 10 and thereafter hydrolyzing said polymeric acetonide under acid conditions to remove the  
 acetonide group, and thereafter subjecting said hydrolyzed acetonide to oxidation with a  
 periodate oxidizing agent to form said aldehyde.

(19) World Intellectual Property  
Organization  
International Bureau



(43) International Publication Date  
19 June 2003 (19.06.2003)

PCT

(10) International Publication Number  
WO 2003/049699 A3

- (51) International Patent Classification<sup>7</sup>: C07C 235/00, 229/00, 69/96
- (21) International Application Number: PCT/US2002/039434
- (22) International Filing Date: 9 December 2002 (09.12.2002)
- (25) Filing Language: English
- (26) Publication Language: English
- (30) Priority Data:  
10-2001-0078244  
11 December 2001 (11.12.2001) KR  
60/348,452 16 January 2002 (16.01.2002) US  
60/381,503 17 May 2002 (17.05.2002) US  
60/407,741 3 September 2002 (03.09.2002) US
- (71) Applicant: SUN BIO, INC. [US/US]; 1685 Suncrest Court, Walnut Creek, CA 94596 (US).
- (72) Inventors: ROSEN, Perry; 26 Sunset Drive, North Caldwell, NJ 07006 (US). NHO, Kwang; 1685 Suncrest Court, Walnut Creek, CA 94596 (US).
- (74) Agents: EPSTEIN, William, H. et al.; Gibbons, Del Deo, Dolan, Griffinger & Vecchione, One Riverfront Plaza, Newark, NJ 07102 (US).
- (81) Designated States (*national*): AE, AG, AL, AM, AT, AU, AZ, BA, BB, BG, BR, BY, BZ, CA, CH, CN, CO, CR, CU, CZ, DE, DK, DM, DZ, EC, EE, ES, FI, GB, GD, GE, GH, GM, HR, HU, ID, IL, IN, IS, JP, KE, KG, KP, KR, KZ, LC, LK, LR, LS, LT, LU, LV, MA, MD, MG, MK, MN, MW, MX, MZ, NO, NZ, OM, PH, PL, PT, RO, RU, SD, SE, SG, SK, SL, TJ, TM, TN, TR, TT, TZ, UA, UG, UZ, VN, YU, ZA, ZM, ZW.
- (84) Designated States (*regional*): ARIPO patent (GH, GM, KE, LS, MW, MZ, SD, SL, SZ, TZ, UG, ZM, ZW), Eurasian patent (AM, AZ, BY, KG, KZ, MD, RU, TJ, TM), European patent (AT, BE, BG, CH, CY, CZ, DE, DK, EE, ES, FI, FR, GB, GR, IE, IT, LU, MC, NL, PT, SE, SI, SK, TR), OAPI patent (BF, BJ, CF, CG, CI, CM, GA, GN, GQ, GW, ML, MR, NE, SN, TD, TG).
- Published:**  
— with international search report  
— before the expiration of the time limit for amending the claims and to be republished in the event of receipt of amendments
- (88) Date of publication of the international search report: 29 December 2004
- For two-letter codes and other abbreviations, refer to the "Guidance Notes on Codes and Abbreviations" appearing at the beginning of each regular issue of the PCT Gazette.*



WO 2003/049699 A3

(54) Title: NOVEL MONOFUNCTIONAL POLYETHYLENE GLYCOL ALDEHYDES

(57) Abstract: Novel monofunctional polyethylene glycol aldehyde for pegylating therapeutically active proteins to produce pegylated protein conjugates which retain a substantial portion of their therapeutic activity and are less immunogenic than the protein from which the conjugate is derived and a new synthesis for preparing such aldehydes.

**INTERNATIONAL SEARCH REPORT**

International application No.

PCT/US02/39434

**A. CLASSIFICATION OF SUBJECT MATTER**

IPC(7) : C07C 235/00, 229/00, 69/96  
 US CL : 564/201; 560/166; 558/266, 276

According to International Patent Classification (IPC) or to both national classification and IPC

**B. FIELDS SEARCHED**

Minimum documentation searched (classification system followed by classification symbols)  
 U.S. : 564/201; 560/166; 558/266, 276

Documentation searched other than minimum documentation to the extent that such documents are included in the fields searched

Electronic data base consulted during the international search (name of data base and, where practicable, search terms used)  
 Please See Continuation Sheet

**C. DOCUMENTS CONSIDERED TO BE RELEVANT**

Category *	Citation of document, with indication, where appropriate, of the relevant passages	Relevant to claim No.
P, X --- A	WO 02/059179 A2 (SHEARWATER CORPORATION) 01 August 2002 (01.08.2002), page 4, lines 17-33, and page 19, line 24-page 20, line 3.	1-20 ----- 33, 52
A	WO 03/044056 A2 (PHARMACIA CORPORATION) 30 May 2003 (30.05.2003), page 36, line 1 and claims.	21-52
A	US 5,135,683 A (COOPER) 04 August 1992 (04.08.1992), entire document.	55-58

Further documents are listed in the continuation of Box C.

See patent family annex.

* Special categories of cited documents:	"T" later document published after the international filing date or priority date and not in conflict with the application but cited to understand the principle or theory underlying the invention
"A" document defining the general state of the art which is not considered to be of particular relevance	"X" document of particular relevance; the claimed invention cannot be considered novel or cannot be considered to involve an inventive step when the document is taken alone
"E" earlier application or patent published on or after the international filing date	"Y" document of particular relevance; the claimed invention cannot be considered to involve an inventive step when the document is combined with one or more other such documents, such combination being obvious to a person skilled in the art
"L" document which may throw doubts on priority claim(s) or which is cited to establish the publication date of another citation or other special reason (as specified)	"&" document member of the same patent family
"O" document referring to an oral disclosure, use, exhibition or other means	
"P" document published prior to the international filing date but later than the priority date claimed	

Date of the actual completion of the international search

20 September 2004 (20.09.2004)

Date of mailing of the international search report

**05 NOV 2004**

Name and mailing address of the ISA/US

Mail Stop PCT, Attn: ISA/US  
 Commissioner for Patents  
 P.O. Box 1450  
 Alexandria, Virginia 22313-1450  
 Facsimile No. (703)305-3230

Authorized officer

Paul A. Zucker  
 Telephone No. (571) 272-1600

*F. Roberto for*

**INTERNATIONAL SEARCH REPORT**

PCT/US02/39434

**Continuation of B. FIELDS SEARCHED Item 3:**  
CAS ONLINE  
search terms: structures